

Industry 4.0 enabling sustainable supply chain development in the renewable energy sector: A multi-criteria intelligent approach

Mastrocinque, E., Ramirez, F. J., Honrubia-Escribano, A. & Pham, D. T

Published PDF deposited in Coventry University's Repository

Original citation:

Mastrocinque, E, Ramirez, FJ, Honrubia-Escribano, A & Pham, DT 2022, 'Industry 4.0 enabling sustainable supply chain development in the renewable energy sector: A multi-criteria intelligent approach', *Technological Forecasting and Social Change*, vol. 182, 121813. <https://doi.org/10.1016/j.techfore.2022.121813>

DOI 10.1016/j.techfore.2022.121813

ISSN 0040-1625

Publisher: Elsevier

© 2022 The Authors. Published by Elsevier Inc. This is an open access article under the CC BY license (<http://creativecommons.org/licenses/by/4.0/>), which permits unrestricted use, distribution, and reproduction in any medium, provided the original work is properly cited..



Industry 4.0 enabling sustainable supply chain development in the renewable energy sector: A multi-criteria intelligent approach

Ernesto Mastrocinque^{a,*}, F. Javier Ramírez^b, Andrés Honrubia-Escribano^c, Duc T. Pham^d

^a Faculty of Engineering, Environment and Computing, Coventry University, Priory Street, Coventry, CV1 5FB, United Kingdom

^b School of Industrial Engineering, Department of Business Administration, Universidad de Castilla-La Mancha, 02071 Albacete, Spain

^c Renewable Energy Research Institute and DIEEAC-ETSII-AB, Universidad de Castilla-La Mancha, 02071 Albacete, Spain

^d Department of Mechanical Engineering, College of Engineering and Physical Sciences, The University of Birmingham, B15 2TT, United Kingdom

ARTICLE INFO

Keywords:

Sustainable supply chain
Industry 4.0
Renewable energy
Triple Bottom Line
Multi-criteria decision-making
Fuzzy logic

ABSTRACT

The aim of this paper is to provide a multi-criteria decision-making intelligent approach based on Industry 4.0 and Triple Bottom Line principles for sustainable supply chain development in the renewable energy sector. In particular, the solar photovoltaic energy supply chain is used as a case study, encompassing the entire energy production process, from supply to disposal. An exhaustive literature review is conducted to identify the main criteria affecting social, economic and environmental sustainability in the photovoltaic energy supply chain, and to explore the potential impact of Industry 4.0 on sustainability. Subsequently, three Fuzzy Inference Systems combining quantitative and qualitative data are built to calculate the supply chain's social, economic and environmental sustainability. Experts' opinions are used to identify the impact of Industry 4.0 technologies on the three pillars of sustainability for each supply chain stage. Finally, a novel sustainability index, Sustainability Index 4.0, is formulated to compute the overall sustainability of the photovoltaic energy supply chain in seven countries. The results show the applicability and usefulness of the proposed holistic model in helping policy makers, stakeholders and users to make informed decisions for the development of sustainable renewable energy supply chains, taking into account the impact of Industry 4.0 and digital technologies.

1. Introduction

Industry 4.0 (I4.0) was first introduced in Germany in 2011 as a key element of the country's high technology plan to improve industrial capability, to influence whole business processes, and to integrate the Internet of Things (IoT) and information technology (IT) services, all in search of an intelligent environment (Luthra et al., 2020). I4.0 entails a digital transformation where the physical world of industrial production merges with the digital world of IT, making it possible to digitise and interconnect production (Herrmann et al., 2014; Kang et al., 2016). Similar strategies to I4.0 have been adopted in China ('Made in China 2025'), India ('Make in India'), US, France, UK, Japan and Singapore (Bag et al., 2021; Luthra and Mangla, 2018).

In the European Union (EU), regional, national and European initiatives have been adopted with the goal of digitising the industry (European Commission, 2016). The Digital Transformation Scoreboard (DTS) (European Commission, 2018) is an approach adopted in the EU

to monitor the transformation of existing industry and enterprises. By the adoption of national indicators, the digital transformation in Europe and the impact of I4.0 is analysed with a geographic focus and from a macro-perspective. The survey gathers information about the impact of nine key emerging technologies—3D printing, Big data and data analytics, Mobile services, Cloud technologies, Social media, Internet of Things, Robotic & automated machinery, and artificial intelligence (AI)—on EU companies' performance, and provides the Digital Technology Integration Index (DTII) as an indicator to rank the uptake of I4.0 technologies by EU Member States.

I4.0 has great potential to influence Supply Chain (SC) networks, business processes and models (Duarte and Cruz-Machado, 2017). I4.0 requires horizontal, vertical, and end-to-end digital integration (Bag et al., 2021), affecting all levels of the SC for total system integration and automation (Luthra et al., 2020), and enhancing the social, economic and environmental benefits leading to a sustainable culture in industrial supply chains (Luthra and Mangla, 2018). A Sustainable Supply Chain

* Corresponding author.

E-mail addresses: ac3445@coventry.ac.uk (E. Mastrocinque), franciscoj.ramirez@uclm.es (F.J. Ramírez), andres.honrubia@uclm.es (A. Honrubia-Escribano), D.T.Pham@bham.ac.uk (D.T. Pham).

<https://doi.org/10.1016/j.techfore.2022.121813>

Received 2 September 2021; Received in revised form 7 June 2022; Accepted 9 June 2022

Available online 16 June 2022

0040-1625/© 2022 The Authors. Published by Elsevier Inc. This is an open access article under the CC BY license (<http://creativecommons.org/licenses/by/4.0/>).

(SSC) entails 'the integration of economic, environmental, and social considerations with key inter-organisational business systems designed to efficiently and effectively manage the material, information, and capital flows associated with the procurement, production, and distribution of products or services in order to meet stakeholder requirements and improve the profitability, competitiveness, and resilience of the organisation over the short- and long-term' (Ahi and Searcy, 2013). In this sense, the adoption of the I4.0 enablers and the analysis of the impact across all levels of the SSC are critical for the successful implementation of digital transformation initiatives (European Commission, 2018).

Renewable energy and energy efficiency are two pillars of the sustainable energy and the key factors to achieve international climate mitigation and sustainable development targets (UNIDO, 2017). Renewable energy capacities have developed enormously in the last decade, particularly solar photovoltaics (PV) with an average growth rate of 46.2 % since 1990 (UNIDO, 2017). Currently, a growing number of countries are producing their electricity from solar PV, with 16 countries adding over 1 GW in 2019 (Solar Power Europe, 2020). A total of 116.9 GW of solar PV capacity was added in 2019, with this being the second time the 100 GW yearly level has been exceeded (Solar Power Europe, 2020). This amount accounted for 48 % of the total power generation capacity added in that year, amounting to a total of 633.7 GW.

In addition to the installed capacity, solar PV accounted for 3 % of the worldwide energy production in 2019 and 5 % in the EU (International Energy Agency, 2020). Behind China, the EU ranked second with 16.0 GW of annual PV installations in 2019 (International Energy Agency, 2020), summing up a total of 131.7 GW. In this sense, 85 % of the current solar PV installed capacity in Europe is provided by seven countries (Germany, Italy, the United Kingdom, France, Spain, Belgium, Greece). For this reason, these seven countries are chosen as case studies for the current work.

The photovoltaic supply chain (PVSC) encompasses all the activities associated with the transformation flows of materials and energy, from manufacturers upstream to downstream actors, such as engineering, procurement and construction companies, project developers, O&M providers, end-users or customers, as well as the end-of-life (EoL) management of the PV power plants (REN21, 2019). Material, energy and information flows go up and down in the PVSC. In the real world, the different members of the PVSC are competing together and the competition between domestic and foreign suppliers to increase efficiency and stay competitive will likely improve trends in the PVSC. The PVSC has been assessed by the authors in the previous work by Mastrocinque et al. (2020) proposing a multi-criteria decision making (MCDM) framework based on the Triple Bottom Line (TBL) principles and Analytical Hierarchy Process (AHP) methodology in order to provide decision-makers with a tool for making sustainable decisions in the PV sector.

Recently, a number of papers have considered the relationship between I4.0, sustainability and supply chains (Chen et al., 2021; Piccarozzi et al., 2022; Soni et al., 2022). A literature review conducted by Bag et al. (2021) found that only limited attention has been paid to managing supply chain sustainability by means of I4.0 technologies. Moreover, it highlighted that previous studies have ignored the social pillar of sustainability. de Sousa Jabbour et al. (2018) carried out a theoretical study to understand the synergy between I4.0 and environmentally-sustainable manufacturing. The authors called for empirical and quantitative works, as well as the integration of social sustainability into the debate, with a TBL perspective. Manavalan and Jayakrishna (2019) reviewed the factors influencing sustainable supply chain for I4.0 requirements and suggested future studies to focus on industry-specific deployment of I4.0. Ghobakhloo (2020) identified the opportunity that I4.0 might represent for sustainability. The study, however, suggested that stakeholders, public and private sectors and academia should work together to ensure that the potential benefits of I4.0 for sustainability are fully achieved and equally and fairly distributed.

Finally, an analysis of the I4.0 drivers to foster supply chain sustainability, with a focus on an emerging economy such as India, was carried out by Luthra et al. (2020). The authors suggested extending the research to other countries, using other MCDM methods, as well as conducting further empirical studies. These recent studies show the increasing attention and interest in understanding whether and how I4.0 may impact sustainability and help achieve sustainable supply chains. However, the majority of the works are theoretical and mostly literature reviews, and the same authors recognise the need for more empirical and quantitative studies, focused on specific industries or sectors, and which consider sustainability from a holistic TBL perspective.

This paper presents one of the first multi-criteria models to consider the impact of I4.0 on the three TBL pillars for developing sustainable PVSCs. Starting from the literature review, the main criteria affecting the social, economic and environmental sustainability across the different stages of the PVSC are identified. Then, three Fuzzy Inference Systems, combining the quantitative and qualitative criteria considered, are built to compute the supply chain's social, economic and environmental sustainability. Furthermore, experts' opinions are used to identify and assess the impact of I4.0 technologies on the three sustainability pillars for each SC stage. Finally, a novel sustainability index, Sustainability Index 4.0, is formulated to compute the overall sustainability of the PVSC and seven countries that together represent 85 % of the total photovoltaic installed capacity in Europe are used as real-world cases.

This paper makes theoretical contributions to the literature, broadening the body of knowledge on the main topics addressed. Firstly, the paper contributes to SCM theory, improving the performance of PVSCs. Secondly, based on the literature review, we provide a selection of the main criteria measuring the sustainability dimensions of the PVSC, grouped under the TBL dimensions of social, economic and environmental. Thirdly, the nine I4.0 technologies as enablers for sustainability are identified and, based on experts' opinions, linked to the identified sustainability criteria across the five stages of the PVSC: supply, generation, distribution, demand and disposal. Fourthly, a sustainability index is built, taking into account the impact of I4.0 and being computed for seven main European countries.

Moreover, this work has significant managerial implications, providing a novel quantitative and powerful tool for users, policy makers and investors in PV energy to solve complex decision problems along the SC, improving the digitisation of energy systems, and opening up opportunities for new business models.

The remainder of the paper is organised as follows. Section 2 presents the literature review with the theoretical background on the main topics addressed in the paper. Section 3 provides the framework of research. Section 4 is devoted to defining the methodology, followed by the case study, results and managerial implications which are addressed in Section 5. Finally, Section 6 concludes the paper by highlighting the research findings and proposing future research directions.

2. Literature review

2.1. Triple Bottom Line and Supply Chain Management

Sustainability entails the use of resources to meet the needs of the present without compromising future generations' ability to meet their own needs (WCED, 1987). The Triple Bottom Line (TBL) concept was first introduced by Elkington (1997) defining the three main components of sustainability as social, economic and environmental in an attempt to emphasise the importance of social and environmental dimensions in addition to the traditional economic issues. Therefore, to achieve the sustainability goals, organisations must be involved in activities promoting environment and society (Govindan et al., 2013). However, as recognised in the literature, many ecological and social aspects can only be understood across the entire supply chain (Govindan and Hasanagic, 2018), and thus TBL shows a strong relationship with Supply Chain Management (SCM) (Birkel and Müller, 2021).

SCM refers to the strategic and systemic coordination of all the business functions, policies and procedures of a particular company, and across businesses within the SC, with the goal of improving the long-term performance of the whole SC and the companies that are involved in all its levels. SCM also enables the integration of customers, manufacturers and suppliers with the aim of improving companies' flexibility and responsiveness (Gunasekaran et al., 2004). Supplier selection is one of the critical decisions that may impact companies' success and help achieve a competitive advantage. Therefore, various approaches and methods, such as MCDM (Fazlollahatabar and Kazemitash, 2021; Kazemitash et al., 2021; Stević et al., 2020) and Fuzzy logic (Ali et al., 2021; Mondragon et al., 2021; Yuce and Mastrocinque, 2016) have been proposed in the literature to address such a decision, considering also sustainability criteria, mainly related to economic and environmental impacts.

Additionally, the literature suggests that sustainable SC network design should incorporate the TBL dimensions, and thus economic, environmental, and social performance must be simultaneously optimised (Darbari et al., 2019), and the balance of all three dimensions is a critical success factor, as sustainability must be considered a concept with strong interdependencies (Birkel and Müller, 2021). From the integration of the three TBL dimensions in the SCM, emerged the Sustainable Supply Chain Management (SSCM) concept, aimed at integrating economic, environmental and social considerations with inter-organisational business systems to efficiently and effectively manage the material, information, and capital flows involved in the different levels of the SC to improve the profitability, competitiveness and resilience of the organisation (Ahi and Searcy, 2013). In this sense, the literature recognises that social, economic and environmental factors must be considered in the performance evaluation of the SSC, in addition to quality, cost and flexibility (Ageron et al., 2012).

2.2. Influence of I4.0 on the renewable energy production

Recently, I4.0 has devoted substantial attention to the field of energy, which involves renewable energy production (Dogaru, 2020). I4.0 has paved the way for the development of modernised electric energy systems able to integrate a larger number of renewable energy sources (Furstenau et al., 2020). I4.0 will contribute to the provision of additional flexibility for renewable energy sources through increased flexibility of production processes (Scharl and Praktiknjo, 2019; Stock et al., 2018). I4.0 also had an impact on the development of digital twins, which will be useful for network operators not only to obtain accurate estimations of industrial energy consumption and generation but also to perform a more effective identification of failures in power systems. In fact, Scharl and Praktiknjo (2019) stated that the digitisation of the industry might provide positive impacts on future renewable energy systems, Hidayatno et al. (2019) contributed to a better understanding of how I4.0 might support the transition to a widespread use of renewable energy sources in Indonesia, and Nara et al. (2021) realised that it is possible to increase the use of renewables by integrating different I4.0 technologies, such as the IoT, sensors, and big data in the Brazilian plastics industry.

Another recent digital approach aimed at further integrating renewable energies is the development of virtual power plants (VPPs) (Kenzhina et al., 2019; UNIDO, 2017). The VPP is defined as a single large power plant interconnecting and controlling dispersed generators through an IT platform. The main motivation for the development of VPPs is to efficiently address the variable consumption profile with the uncertainty of the power generated by non-manageable renewable energy power plants. In this sense, the I4.0 can rapidly adapt to fast changes in the energy supply by switching to other energy intensive processes and therefore contributing to the security of energy supply. In addition, real-time data related to the energy consumed by customers may be useful to optimise the renewable energy sources.

2.3. Potential of I4.0 for Sustainable Supply Chain Management

The relationship of I4.0 with the concepts of SCM and TBL has been thoroughly studied in the literature from both perspectives (Birkel and Müller, 2021). First, I4.0 has been assessed as an enabler of vertical and horizontal integration of real-time information and communication technologies along the SC networks. As result, I4.0 enables companies to achieve economic goals and revenue growth (Bonilla et al., 2018). Second, the multitude of interrelations of I4.0 with the TBL of sustainability has been recognised in the literature, mainly influenced by society, increasing the awareness of the environmental dimension, such as the finite nature of the resources, and the social dimension as the concern about the number of job losses generated by process automation (Bag et al., 2021). Despite the extensive literature on both relationships, these three concepts have not adequately been combined in order to assess how I4.0 contributes jointly to the sustainable development of the social, economic and environmental SCM goals, as highlighted in the work by Birkel and Müller (2021). The main challenge in merging these three concepts is the identification and selection of the most suitable technologies that may best impact on the social, economic and environmental aspects of sustainability (Sung, 2018). The literature recognises the lack of investigation on the disruption of I4.0 technologies' in the SC, and the difficulty involved in companies identifying the I4.0 enablers in developing a SSC (Caiado et al., 2021), which creates an opportunity for research, offering solutions that allow the integration of I4.0 technologies with the aim of achieving a more sustainable supply chain, as the present work proposes.

2.4. Decision making approaches in the renewable energy context

The development of decision-making models in the area of renewable energy has recently gained much attention. The most relevant studies encompassing the concepts of SC, TBL, PV and I4.0 are summarised in Table 1.

From the analysis of the literature, a number of different decisions, such as RE planning, SC design technology selection, source selection, in the context of RE have been addressed using different methodologies. Multi-criteria decision making (MCDM) have proved to be an effective approach in the context of sustainable renewable energy development (Kumar et al., 2017). The most commonly used methods are AHP, ANP, TOPSIS, DEMATEL. Moreover, Fuzzy logic has also proven to be a valid and widely used approach when it comes to dealing with uncertainty, as shown in Table 1.

A number of works have considered SC and TBL in the RE context. Mafakheri and Nasiri (2014) conducted a review of the modelling of biomass supply chain operations identifying the need for future research on the impact of technological change, as well as more sustainable design and management of the biomass supply chain. Wang et al. (2018) developed a MCDM approach under fuzzy environments for wind power plant location selection in Vietnam and suggested the development of models including new factors or different methodologies for the analysis of diverse scenarios regarding energy issues.

Other authors have focused their attention on SC and PV energy. Dehghani et al. (2018) presented a two-phase approach based on data envelopment analysis (DEA) and robust optimisation to design and plan a solar photovoltaic supply chain in an uncertain environment, recommending as future research to consider environmental impacts as well as fuzzy logic to cope with lack of knowledge of the input parameters. Dehghani et al. (2020) developed a multi-objective robust mathematical model to minimise the environmental impacts and cost objectives in a solar photovoltaic supply chain under correlated uncertainty, suggesting the incorporation of social aspects. Xu and Ma (2021) established a novel solar photovoltaic supply chain structure in practice, where the households not only consume electricity but also generate energy to the utility, based on a nonlinear dynamic system considering economic factors.

Table 1
Summary of the relevant sources and gaps in the literature.

Study	Topic	Methodology	Approach			
			SC	TBL	PV	I4.0
(This paper)	PVSC development	Fuzzy Inference Systems, MCDM	X	X	X	X
Tsao et al. (2021)	RE supply network design	Fuzzy programming model	X		X	
Xu and Ma (2021)	PVSC planning	Non-linear dynamic modelling	X		X	
Alizadeh et al. (2020)	RE planning	BOCR, ANP		X	X	
Dehghani et al. (2020)	PVSC optimisation	Multi-objective mathematical model	X		X	
Mastrocinque et al. (2020)	PVSC development	AHP	X	X	X	
Wang et al. (2019)	Wind power plant supplier selection	Fuzzy MCDM	X			
Chen and Su (2018)	PVSC business dynamics	Game theory	X		X	
Dehghani et al. (2018)	PVSC design	DEA	X		X	
Hocine et al. (2018)	RE portfolio selection	Fuzzy Goal Programming		X	X	
Wang et al. (2018)	Wind power plant location	MCDM, Fuzzy logic	X	X		
Büyükoğuzkan and Güleriyüz (2017)	RE selection	Fuzzy logic, DEMATEL, ANP, TOPSIS		X	X	
Çolak and Kaya (2017)	RE alternative prioritization	AHP, Fuzzy sets, Fuzzy TOPSIS		X	X	
Kumar et al. (2017)	Sustainable RE SC development	Review		X	X	
Balaman and Selim (2016)	Biomass energy SC design	Fuzzy MILP	X			
Ahmad and Tahar (2014)	RE source assessment	AHP		X	X	
Mafakheri and Nasiri (2014)	Biomass SC operations	Review	X	X		

Moreover, several works have considered TBL and PV energy. Çolak and Kaya (2017) proposed an integrated MCDM model based on AHP and interval type-2 fuzzy sets and hesitant fuzzy TOPSIS methods for prioritization of renewable energy alternatives in Turkey, finding that wind, followed by solar energy are the best renewable energy alternatives and suggested the application of different fuzzy MCDM methodologies as future research. Hocine et al. (2018) proposed an efficient method, called multi-segment fuzzy goal programming (MS-FGP), which addresses decision-making problems with high levels of uncertainty, for searching for the best portfolio of renewable energy focusing on the case of Italy. Moreover, the authors recommended applying the proposed model to other fields, such as supply chain management. Alizadeh et al. (2020) presented a framework based on Benefit, Opportunity, Cost, Risk (BOCR) and Analytic Network Process (ANP) models for renewable energy planning and decision-making using Iran as case study, and found solar, followed by wind energy, as the priority sources.

Finally, Mastrocinque et al. (2020) focused on SC, TBL and PV providing a multi-criteria decision-making framework based on the Triple Bottom Line principles and Analytic Hierarchy Process methodology for sustainable supply chain development in the PV energy sector, assessing seven European countries and different scenarios. As future research opportunities, the authors suggested considering fuzzy logic to deal with the uncertainty of the input data and experts' judgement, and modifying the model to address other decisions or sectors.

The analysis of the research works in Table 1 reveals that only one study has considered SC, TBL and PV simultaneously and that I4.0 has

been neglected. The gaps identified in the literature and the recommendations for future research proposed in the prior studies suggest the need for further models and methodologies addressing decision-making in the renewable energy context, from a sustainable supply chain perspective. In particular, the social aspects of sustainability and the impact of technological change require greater consideration. Moreover, the works analysed have focused on case studies concerning a single country. Our work responds to such gaps and recommendations by proposing an intelligent approach for developing a PV supply chain taking into account not only all the TBL pillars, but also the potential impact that Industry 4.0 and digital technologies might have on each sustainability criterion at each stage of the SC. Moreover, a multi-country comparative analysis is carried out, rather than focusing on a single country. Furthermore, fuzzy logic has been identified as a valid tool for treating uncertainty of the data and is therefore applied as part of our proposed approach.

3. PV-SSC management framework

In the literature, the photovoltaic SC is considered a complex system that is different from other SCs (Mastrocinque et al., 2020), in which a mix of public and private partners, major and minor players, and different drivers, are involved along the value chain steps. According to Hassini et al. (2012), the most important functions within the SSC are sourcing, transformation, delivery, value proposition, customers, and recycling. Based on this, we propose the photovoltaic sustainable supply chain (PV-SSC) framework as shown in Fig. 1, where the main steps of the SC –Supply, Generation, Distribution, Demand and Disposal–, and the different tiers, partners and players are identified. Additionally, and based on the three TBL dimensions of sustainability, we analyse the main factors that impact each step of the PV-SSC, grouping them into the social, economic and environmental dimensions of sustainability. In addition, I4.0 enablers for sustainable SC are identified in order to analyse their impact along the SC steps.

In the following sections, the most representative criteria to measure the sustainability dimensions along the PV-SSC are identified. Additionally, in Appendix A, these criteria are quantified and justified, based on the literature review and data obtained from the most important reports and sources addressing the solar photovoltaic market and the development of the industry in recent years. These criteria are grouped according to the three sustainability dimensions. Additionally, the impact of each criterion in the PV-SSC steps is defined. Furthermore, the I4.0 technologies as enablers for PV-SSC are identified.

3.1. Social criteria

There is currently increasing pressure to include social aspects and socially responsible behaviours in organisations, and to implement corporate social responsibility (CSR) at the different levels of the SC (Zhu and Lai, 2019). In the literature, different criteria are used to measure the social dimension of sustainability in SCM (Brandenburg and Rebs, 2015; Govindan et al., 2013; Mastrocinque et al., 2020), understood as the impacts of the organisation on the social system within which it operates (GRI, 2013).

Social criteria are related to internal and external aspects (Brandenburg and Rebs, 2015). Within internal factors, this research considers employment and job opportunities (SOC-1), wage level (SOC-2), and gender employment gap (SOC-3). Moreover, external factors involve stakeholder influence (SOC-4), social acceptability (SOC-5), and population growth (SOC-6). These criteria are justified and quantified in Appendix A.1.

3.2. Economic criteria

Economic factors have traditionally been considered the primary factor for the promotion of PV projects and the main driving force in

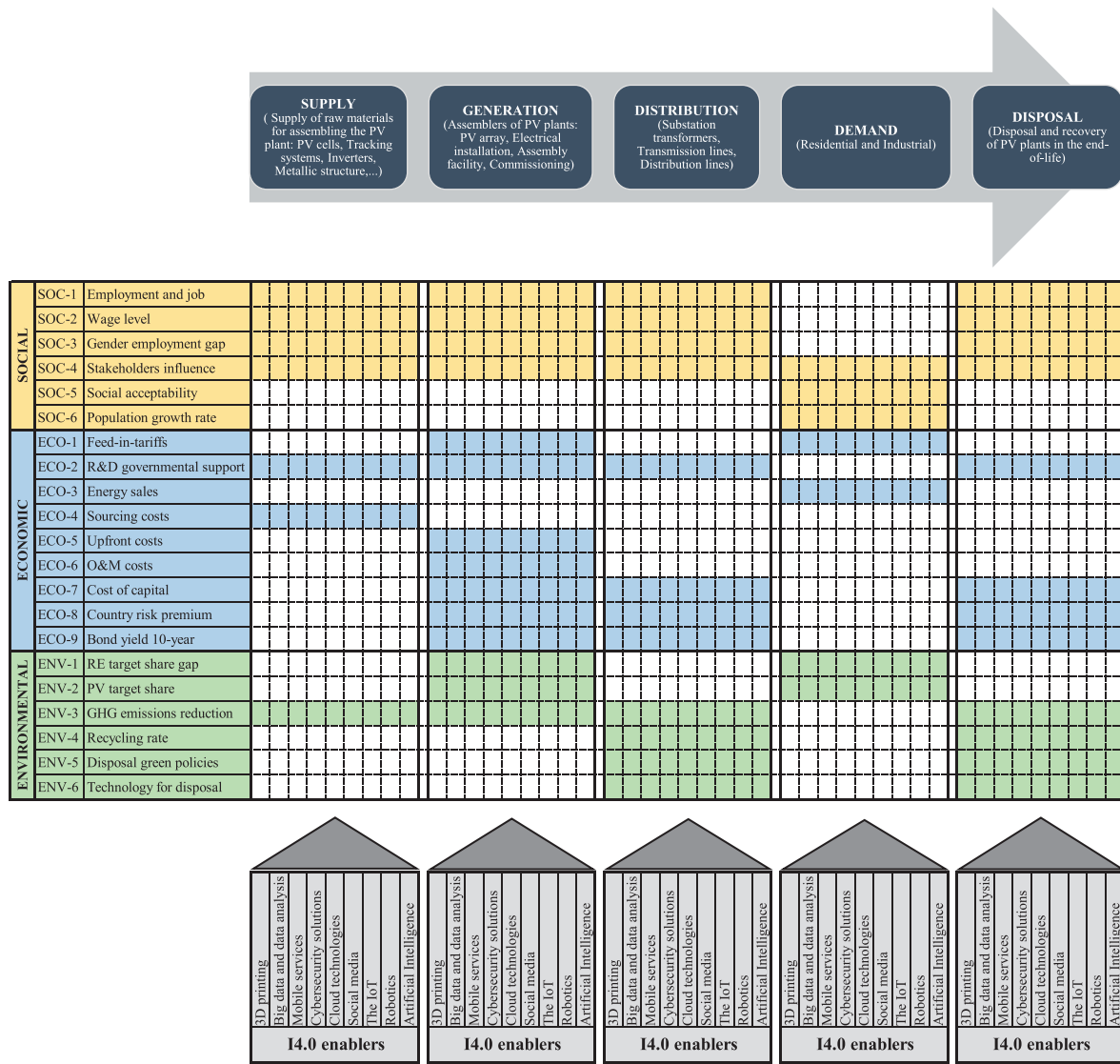

Fig. 1. Photovoltaic sustainable supply chain framework.

making decisions on PV technology penetration in markets. In assessing the PV-SSC, economic outcomes are greatly supported by three drivers: the *revenues* the promoter receives in the form of feed-in-tariffs (ECO-1), governmental support for R&D (ECO-2), or the energy sales (ECO-3) during the PV plant lifetime; the *costs* involved in building and operating the plant, as sourcing costs (ECO-4), upfront costs (ECO-5) and O&M costs (ECO-6); and the parameters that most impact on *financing* PV project, as the cost of debt (ECO-7), country risk premium (ECO-8) and the long-term government bond yield (ECO-9) in the selected country. These criteria are justified and quantified in [Appendix A.2](#).

3.3. Environmental criteria

Environmental factors are a key dimension in SSCM, addressing the total life cycle of the analysed product/process, including its use and end-of-life treatment ([European Commission, 2012](#)). The literature on the environmental aspects of the SC is extensive, with diverse works identifying environmental issues as significant drivers for the adoption of SSCM ([Dubey et al., 2017](#)), developing practices attempting to *integrate environmental concerns into organisations by reducing unintended negative consequences on the environment of production and consumption processes* ([Genovese et al., 2017](#)). In our research, two sub-dimensions are considered in the environmental criteria assessment: *compliance*

with the environmental goals in RE target share (ENV-1), PV target share (ENV-2) and reduction in GHG emissions (ENV-3), and *prevention* practices in form of the recycling rate (ENV-4), green disposal policies (ENV-5), and technology for disposal (ENV-6). These criteria are justified and quantified in [Appendix A.3](#).

3.4. 14.0 technologies as enablers for PV-SSC

The basic principle of I4.0 in the modern industry is to enable the vertical and horizontal integration of manufacturing and services systems driven by the interchange of real data and flexible resources in order to place customised products in the market ([Li et al., 2017](#); [de Sousa Jabbour et al., 2018](#); [Thoben et al., 2017](#)). Following the guidelines of the [European Commission \(2018\)](#), we identify nine I4.0 enablers as the ways to achieve digital transformation in the PV-SSC, as follows:

- **Social media**, with a wide-ranging impact on entrepreneurs providing better knowledge of customer behaviour, including company-wide beyond marketing and community building functions, and allowing for real time information and data sharing.

- Mobile services, which enable the transformation of traditional businesses and whose use is a prime indicator of how digital technologies are influencing companies.
- Cloud technologies, to promote the use of centralised, coordinated applications, and to access data, information and documents from virtually any place.
- Internet of Things, as an information technology (IT) infrastructure to collect and share data between devices to enable identification, localisation, monitoring and tracking of objects.
- Cybersecurity solutions, to protect companies' valuable digital assets given the incremental use of hybrid cloud architectures and the need to manage the security of many more devices.
- Robotics and automated machinery, as an attempt to improve quality and reduce manufacturing costs in end-user industries, adopting robots for industrial applications to change the labour/capital mix.
- Big data and data analytics to gain business insights, leveraging what computers do best while freeing decision-makers from complex analysis of data delivering “intelligence on time”.
- 3D printing, as a new technology transforming the design, development, manufacturing and distribution of products, producing parts faster in any available place.
- Artificial intelligence, which leads to many benefits such as customised products, distributed and localised production based on smart new business models that empower citizens and communities,

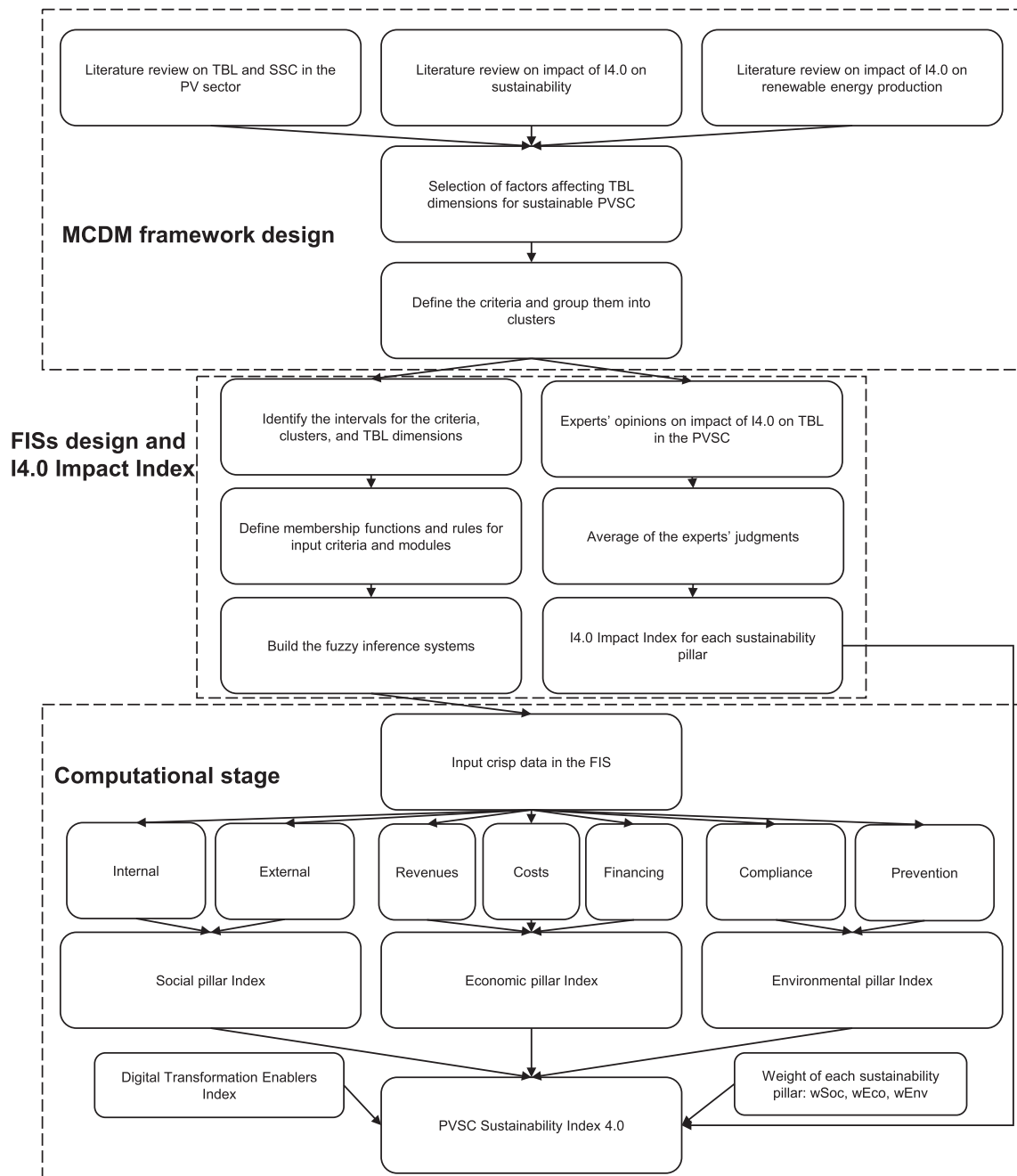

Fig. 2. Proposed methodology flowchart.

as well as improved knowledge and facility sharing. In addition, AI generates clear, indirect consumer benefits from more flexible, responsive and custom-made goods manufacturing, with less delay, fewer defects and faster delivery.

Based on experts' judgements, the influence of these I4.0 enablers on the social, economic and environmental sustainable criteria is assessed in order to quantify the impact of I4.0 along the PV-SSC, as explained in the following sections.

4. Methodology

This section details the methodology developed and shown in Fig. 2.

4.1. MCDM framework for PV-SSC development

The criteria affecting the TBL pillars in the PV-SSC were selected following the literature review presented in the previous section. Subsequently, for each of the pillars, the criteria of the same nature were grouped into clusters such as Internal and External Social clusters, Revenues, Costs and Financing Economic clusters, Prevention and Compliance Environmental clusters.

4.2. Fuzzy logic and FIS background

Fuzzy logic was developed by Zadeh (1965) with the benefit of emulating human reasoning when it deals with entities affected by uncertainty and vagueness. It allows variables of a different nature, such as quantitative and qualitative elements, to be combined with different units of measurement, and it is therefore suitable for our purpose. Fuzzy logic is based on the concept of linguistic variable and membership function. For example, a variable may assume certain linguistic values (e.g. Very Low, Low, Medium, High, Very High). A membership function for each linguistic value is defined in order to express the degree of membership of each value in an interval [0,1] to the linguistic variable, as shown in Figs. 3, 4 and 5. For example, within a minimum value of 0 and a maximum of 1, SOCIAL index equal to 0.4 might be considered to belong to the fuzzy sets corresponding to the linguistic variables Low and Medium, with different degrees of membership, namely 0.4 and 0.6.

Fuzzy logic is often implemented in Fuzzy Inference Systems, with the aim of mapping input-output linguistic variables using If-Then rules (Mamdani and Assilian, 1993; Takagi and Sugeno, 1985). A FIS takes crisp data as input which are then fuzzified through a fuzzification

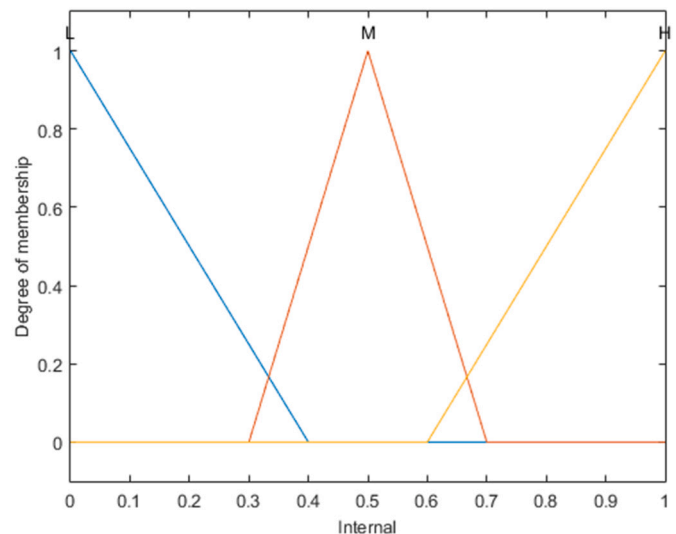

Fig. 4. Membership function for internal cluster.

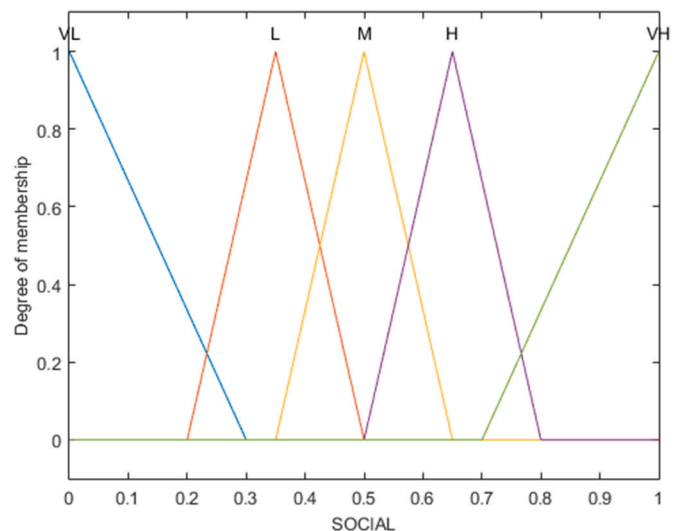

Fig. 5. Membership function for social pillar.

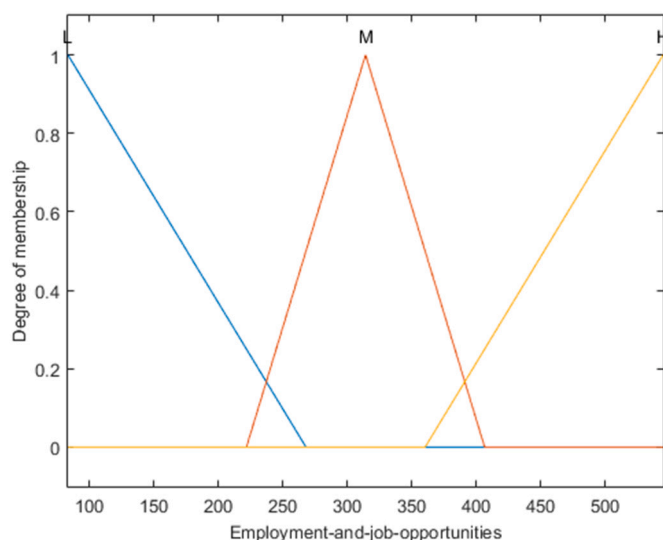

Fig. 3. Membership function for Employment and job opportunities.

process consisting in the computation of the degree of membership of the input crisp data with respect to the corresponding linguistic variables in the If part of the rules. Mamdani fuzzy inference (Mamdani and Assilian, 1993) has been selected for our approach as it has proven to be a valid method for including both quantitative and logical expert knowledge. The If-Then rules are defined based on the trend of the output variable in relation to the decrease or increase in the input variables. As an example, the rules defined within the FIS ECO1–3 are listed in Appendix B.

Once an output membership function has been calculated, a crisp value which best represents the corresponding fuzzy set is determined through a defuzzification process based on the Centroid method.

4.3. Fuzzy Inference Systems for TBL pillars computation

In this research, three modular FISs were designed, one for each TBL pillar, as shown in Fig. 6. For each pillar, the crisp values of the corresponding criteria are given as input to the first layer of FISs, which gives as output the crisp values of the corresponding clusters. Subsequently, the values of the clusters are given as input to another FIS module which finally calculate the desired pillar index. Overall, 10 FISs were designed,

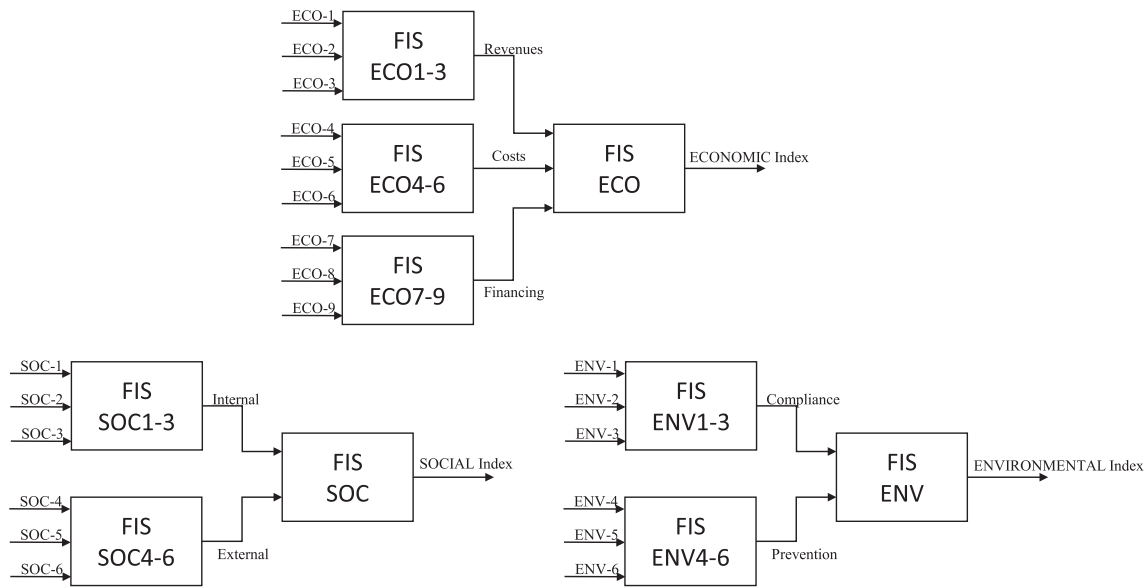

Fig. 6. Fuzzy Inference Systems for TBL pillars computation.

taking 21 variables as input, corresponding to the decision-making criteria. A minimum of $3^2 = 9$ rules were defined for a two-input FIS, and a maximum of $3^3 = 27$ rules for a three-input FIS; 234 rules were defined overall. Grouping the criteria into clusters significantly reduced the number of rules needed. In fact, a maximum of $3^9 = 19683$ rules for the Economic pillar and $2 \times 3^6 = 1458$ rules for the Social and Environmental pillars could have been defined without clusters, considering 3 linguistic variables.

4.4. PVSC Sustainability Index 4.0

Four experts were approached and asked to identify the links between each I4.0 key technology and the sustainability criteria for each relevant stage of the PV-SSC, in order to quantify the impact of I4.0 on sustainability in the PV-SSC, as shown in Fig. 7.

The overall PV-SSC Sustainability Index 4.0 is calculated as follows, Eq. (1).

$$SI4.0 = (1 + DTEI) \cdot [(1 + IAI_{SOC}) \cdot w_{SOC} \cdot SOCI + \dots + (1 + IAI_{ECO}) \cdot w_{ECO} \cdot ECOI + (1 + IAI_{ENV}) \cdot w_{ENV} \cdot ENVI] \tag{1}$$

where:

- *SOCI*, *ECOI* and *ENVI* are the normalised TBL indices obtained by the FISs. Their value is between 0 and 1, with the sum equal to 1.
- w_{SOC} , w_{ECO} and w_{ENV} are weights representing the importance assigned by the decision maker to the TBL pillars. Their value is between 0 and 1, with their sum equal to 1.
- IAI_{SOC} , IAI_{ECO} and IAI_{ENV} are the normalised I4.0 Impact indices for each TBL pillar in the PV-SSC. Their value is between 0 and 1, with the sum equal to 1.
- *DTEI* is the Digital Transformation Enablers Index, indicating the percentage of enabling conditions for digital transformation present in a certain country (Probst et al., 2018). Its value is between 0 and 1.

			SUPPLY	GENERATION	DISTRIBUTION	DEMAND	DISPOSAL					
SOCIAL	SOC-1	Employment and job opportunities	Maximise	2 3 3 2 2 3 2 2 1 2	1 2 2 2 2 2 2 2 2 2	0 3 3 3 1 2 1 1 2	0 0 0 0 0 0 0 0 0	1 3 2 2 2 2 2 2 2 2				
	SOC-2	Wage level	Maximise	1 2 2 1 2 1 2 0 2	1 2 2 2 2 1 1 2 2 2	0 2 2 2 2 2 1 1 1 1	0 0 0 0 0 0 0 0 0	0 2 3 2 2 1 2 2 2 2				
	SOC-3	Gender employment gap	Minimise	0 3 2 0 2 3 0 1 2	1 2 1 2 1 2 1 1 2	0 1 2 1 2 3 0 0 1	0 0 0 0 0 0 0 0 0	0 2 2 1 2 3 0 1 1				
	SOC-4	Stakeholders influence	Maximise	0 4 3 1 3 1 2 0 1	0 3 2 2 2 1 0 1 2	0 1 2 2 2 1 1 1 2	0 2 3 1 2 2 1 0 2	1 3 3 1 2 2 2 1 3				
	SOC-5	Social acceptability	Maximise	0 0 0 0 0 0 0 0 0	0 0 0 0 0 0 0 0 0	0 0 0 0 0 0 0 0 0	1 4 3 3 2 4 3 0 2	0 0 0 0 0 0 0 0 0				
	SOC-6	Population growth rate	Maximise	0 0 0 0 0 0 0 0 0	0 0 0 0 0 0 0 0 0	0 0 0 0 0 0 0 0 0	1 4 2 1 1 1 1 1 1	0 0 0 0 0 0 0 0 0				
ECONOMIC	ECO-1	Feed-in-tariffs	Maximise	0 0 0 0 0 0 0 0 0	0 3 2 1 2 1 1 1 1	0 0 0 0 0 0 0 0 0	0 2 2 1 1 2 1 0 1	0 0 0 0 0 0 0 0 0				
	ECO-2	R&D governmental support	Maximise	0 3 1 1 2 2 1 0 1	0 3 2 2 2 1 2 2 2	0 2 2 1 1 2 2 1 1	0 0 0 0 0 0 0 0 0	1 3 1 1 2 2 1 1 2				
	ECO-3	Energy sales	Maximise	0 0 0 0 0 0 0 0 0	0 0 0 0 0 0 0 0 0	0 0 0 0 0 0 0 0 0	0 4 2 2 2 2 2 0 2	0 0 0 0 0 0 0 0 0				
	ECO-4	Sourcing costs	Minimise	3 3 3 3 1 3 1 3 2 2	0 0 0 0 0 0 0 0 0	0 0 0 0 0 0 0 0 0	0 0 0 0 0 0 0 0 0	0 0 0 0 0 0 0 0 0				
	ECO-5	Upfront costs	Minimise	0 0 0 0 0 0 0 0 0	3 3 2 2 2 4 2 3 3 2	0 0 0 0 0 0 0 0 0	0 0 0 0 0 0 0 0 0	0 0 0 0 0 0 0 0 0				
	ECO-6	O&M costs	Minimise	0 0 0 0 0 0 0 0 0	2 3 4 2 4 2 4 1 2	0 0 0 0 0 0 0 0 0	0 0 0 0 0 0 0 0 0	0 0 0 0 0 0 0 0 0				
	ECO-7	Cost of capital	Minimise	0 0 0 0 0 0 0 0 0	1 4 1 3 3 1 2 1 2	0 3 0 3 3 1 2 0 1	0 0 0 0 0 0 0 0 0	0 4 2 1 3 1 1 2 1				
	ECO-8	Country risk premium	Minimise	0 0 0 0 0 0 0 0 0	1 4 2 1 3 1 1 1 2	0 3 0 2 3 1 1 0 1	0 0 0 0 0 0 0 0 0	0 4 2 1 3 1 1 1 1				
	ECO-9	Long term gov. bond yield 10-year	Minimise	0 0 0 0 0 0 0 0 0	0 4 1 2 3 1 0 0 2	0 3 0 2 3 1 0 0 1	0 0 0 0 0 0 0 0 0	0 4 1 1 3 1 0 1 1				
ENVIRONMENTAL	ENV-1	RE target share gap	Minimise	0 0 0 0 0 0 0 0 0	1 4 3 0 3 2 2 2 3	0 0 0 0 0 0 0 0 0	0 4 3 2 2 3 3 0 2	0 0 0 0 0 0 0 0 0				
	ENV-2	PV target share	Maximise	0 0 0 0 0 0 0 0 0	1 4 3 0 3 2 3 1 2	0 0 0 0 0 0 0 0 0	0 4 2 1 2 3 4 0 2	0 0 0 0 0 0 0 0 0				
	ENV-3	GHG emissions reduction	Maximise	1 3 3 0 3 1 2 2 3	1 3 3 2 3 1 2 2 3	0 3 4 3 4 2 3 2 2	0 0 0 0 0 0 0 0 0	1 3 3 2 3 2 3 2 3				
	ENV-4	Recycling rate	Maximise	0 0 0 0 0 0 0 0 0	0 0 0 0 0 0 0 0 0	2 3 3 1 4 2 1 2 3	0 0 0 0 0 0 0 0 0	3 4 2 1 4 2 3 2 3				
	ENV-5	Disposal green policies	Maximise	0 0 0 0 0 0 0 0 0	0 0 0 0 0 0 0 0 0	2 3 4 1 4 2 2 1 3	0 0 0 0 0 0 0 0 0	2 4 3 1 4 2 3 2 3				
	ENV-6	Technology for disposal	Maximise	0 0 0 0 0 0 0 0 0	0 0 0 0 0 0 0 0 0	2 4 3 2 4 2 3 2 2	0 0 0 0 0 0 0 0 0	4 4 4 1 4 3 3 4 3				
			3D printing	Big data and data analysis	Mobile services	Cybersecurity solutions	Cloud technologies	Social media	The IoT	Robotic and automated machinery	Artificial intelligence	Industry 4.0/Digitalization key technologies

Fig. 7. Overall results of the experts' surveys.

5. Case study

5.1. Countries selected for study

The seven most representative countries in Europe in terms of PV installed power are proposed as the case study in this research. In this sense, Germany, Italy, UK, France, Spain, Belgium and Greece were selected as they represent 85 % of the total PV installed capacity in Europe at the end of 2019 (International Energy Agency, 2020). Furthermore, the first four countries are included in the top ten world cumulative PV capacity.

In 2019, the largest national contribution of solar PV to the electricity demand in Europe was from Germany, which ranked third in the world, accounting for a penetration level of 8.6 % (International Energy Agency, 2020). In terms of yearly installed capacity, Germany was the second European solar PV market in 2019, installing 3.9 GW (49.2 GW total cumulative), representing a significant increase for the third year in a row. The success of the solar PV market in Germany is mainly based on the FIT scheme (Solar Power Europe, 2020), which considers a feed-in tariff for PV systems up to 100 kW, a feed-in premium for systems between 100 kW and 750 kW, and a tendering mechanism for PV systems above 750 kW. Therefore, the current German PV market is currently partially driven by competitive tenders for utility-scale PV plants, which supplement a dynamic self-consumption-based market for rooftop applications (IEA, 2020).

In the case of Italy, the second solar PV market in Europe regarding cumulative installed capacity with 20.8 GW, solar PV accounted for 7.5 % of the electricity generation in 2019 (International Energy Agency, 2020). A new regulation was approved in 2019 to specifically support energy from new, repowered and upgraded RES-based power plants from mature technologies, which includes solar PV power plants with a capacity over 20 kW (IEA, 2019d). In addition, tax discounts have recently been created in Italy to motivate the implementation of residential solar PV systems coupled with electricity storage (IEA, 2020), aiming for a larger integration of renewable energies into the grid.

UK is the third European country in terms of total installed solar PV capacity with 13.3 GW (International Energy Agency, 2020). However, the contribution to the demand coverage in this country was below the 5 % threshold in 2019. The current solar PV market in UK is mostly focused on small-scale applications (IEA, 2020).

A similar situation is found in France. Although this country presents a significant amount of cumulative solar PV capacity installed (with 9.9 GW it is the last top ten country in the world), the contribution of solar PV to the French electricity demand in 2019 was only 2.4 % (IEA, 2019b).

The largest European solar PV market in 2019 was Spain with 4.4 GW installed that year (International Energy Agency, 2020), which is a key change in comparison to the previous years. Most of the solar PV installations implemented in 2019 are utility-scale plants under tenders (IEA, 2020), of the manufacturers of solar PV inverters that existed in 2008, 56 % are no longer present in the market. The contribution of solar PV to the Spanish electricity demand in 2019 was 4.8 %.

In the case of Belgium, with a moderate value of total cumulative installed solar PV capacity of 4.8 GW, 5.7 % of the electricity demand was covered by solar PV in 2019 (International Energy Agency, 2020). Belgium is aiming to increase the integration of solar PV in the coming years, which is demonstrated through the recent implementation of a temporary bonus granted for the purchase of batteries (IEA, 2020).

Finally, the situation of Greece regarding the solar PV market should be highlighted. With only 2.8 GW of cumulative solar PV installed capacity, solar PV covered 8.1 % of the electricity demand in 2019 (International Energy Agency, 2020). The case of Greece is particularly interesting in Europe, in which several islands have significant amounts of solar PV capacity installed, but not connected to the mainland grid (IEA, 2020).

5.2. Data collection for the assessment of the sustainable sub-criteria

Once the countries under study were selected, the next step was to collect the data in order to quantitatively assess the impact of each sub-criterion identified in Section 3 in the chosen countries. In this sense, Table 2 shows the value of the social, economic and environmental sub-criteria for each country and their measurement units. In addition, the sources of information and data to complete this table are detailed in the last column. As explained in Section 3, the impact of the criteria SOC-4, ENV-5 and ENV-6 in each country was assessed in qualitative terms with the help of experts' opinions and using linguistic labels. Data were obtained from the recent research by the authors in Mastrocinque et al. (2020).

5.3. Expert surveys

An expert survey was launched in order to assess the impact of the I4.0 Digitalization Key Technologies on the TBL sub-criteria along the PV-SSC. To fulfil the survey, four experts from academia and the industry were invited to complete the questionnaire. The profile of each expert is as follows:

- Expert 1 is a highly regarded academic and senior researcher in digitisation and I4.0. She works in a university and a computer science research centre.
- Expert 2 is a researcher in I4.0 applied to the reverse supply chain. She works in a research centre.
- Expert 3 is an expert on renewable energy sources. She is the technical manager of a photovoltaic energy engineering company with operations in several European countries.
- Expert 4 is a senior academic and researcher in photovoltaic energy. He works in a renewable energy institute and teaches at a university.

Fig. 7 shows the merged answers from the experts. Each expert was asked to score 1 if a link between the I4.0 enabler and the sub-criterion occurs, and leave blank otherwise. In each of the cells, as presented in Fig. 7, the overall result ranges from 0 to 4 the following step adds all the links for each sub-criterion and calculate the total number of links for each pillar (Social, Economic or Environmental). Subsequently, this number is divided by the maximum number of links available for the specific pillar, obtaining a value representing the impact of I4.0 on TBL in the PV-SSC. Finally, the I4.0 Impact Index for each pillar is calculated by the averages of the values obtained by the four experts.

5.4. Results and analysis

Following the methodology outlined in Section 4, the criteria clusters and the Social, Economic and Environmental indices were computed by the Fuzzy Inference Systems for each of the considered countries. The values are presented in Table 3.

Subsequently, the I4.0 Impact index for each pillar was computed, based on the experts' ratings shown in Fig. 7, obtaining $I4I_{SOC}$ of 0.4108, $I4I_{ECO}$ of 0.4137 and $I4I_{ENV}$ of 0.6032. Therefore, according to the experts, I4.0 technologies might have a higher positive impact on the Environmental side of sustainability compared to Social and Economic for the PV-SSC.

Furthermore, the results of analysis of the I4.0 Impact index for each pillar and each of the five levels of the PV-SSC (supply, generation, distribution, demand and disposal) reveals that the I4.0 enablers might have a higher impact on the Environmental TBL pillar, with values equal to 0.500, 0.546, 0.625, 0.514 and 0.694 for the five consecutive levels. Moreover, the lowest I4.0 Impact index is obtained in the social pillar for the supply and generation SC levels, and for the Economic TBL pillar in distribution, demand and disposal.

Additionally, analysing the influence of the nine I4.0 enablers along the different levels of the PV-SSC, the following findings are obtained:

Table 2
Assessment of the sustainable sub-criteria in the selected countries.

Sub-criteria	Unit	Country								Source
		Germany	Italy	UK	France	Spain	Belgium	Greece		
Social	SOC-1	Lplaces/year//Minhab	545.19	83.40	165.56	108.34	160.86	524.02	186.57	IEA (2019a,b,c,d,e); IRENA (2018)
	SOC-2	€/month	50,700.00	31,050.00	44,784.00	39,308.00	26,922.00	48,645.00	21,279.00	Expansion (2020)
	SOC-3	%	8.10	19.80	9.90	7.60	12.10	8.40	21.00	Eurostat (2019a)
	SOC-4	Logical	0.313	0.191	0.132	0.065	0.203	0.058	0.040	Mastrocinque et al. (2020)
	SOC-5	%	8.90	7.50	2.70	2.10	3.00	4.30	7.40	IEA (2019f)
	SOC-6	%	2.70	-2.10	5.60	1.50	5.90	6.10	-1.80	Eurostat (2018)
Economic	ECO-1	€/kWh	0.12	0.09	0.05	0.19	0.05	0.05	0.11	IEA (2019f) OFGEM (2020) PVTECH (2020) Ministry of Economic Development (2019)
	ECO-2	€/year//Minhab	0.60	0.12	0.17	0.13	0.46	0.33	0.10	Mastrocinque et al. (2020)
	ECO-3	€/kWhp-year	346.47	340.78	229.39	232.45	455.37	320.24	285.29	European Commission (2016)
	ECO-4	€/Wp	0.44	0.35	0.47	0.37	0.29	0.56	0.33	IEA (2019f)
	ECO-5	€/Wp	1.14	1.20	1.25	1.50	1.38	1.13	0.65	IEA (2019a,b,c,d,e); IRENA (2019); Psomas (2018)
	ECO-6	€/kW/year	37.00	38.11	42.92	48.10	44.40	48.10	37.00	Ramírez et al. (2017)
	ECO-7	%	4.50	9.00	6.50	5.70	8.00	6.00	12.00	Expansion (2020)
	ECO-8	-	0.00	194.00	80.00	51.00	121.00	55.00	270.00	Expansion (2020)
	ECO-9	%	-0.47	0.96	0.57	-0.18	0.27	-0.13	1.07	Eurostat (2020a)
Environmental	ENV-1	%	1.52	-0.78	3.98	6.41	2.55	3.58	0.00	Eurostat (2019b)
	ENV-2	%	20.46	20.12	11.99	9.71	12.80	22.58	24.49	Eurostat (2020c)
	ENV-3	%	0.06	0.03	0.18	-0.02	0.01	0.03	0.07	EEA (2020)
	ENV-4	%	66.00	44.00	44.00	40.00	34.00	53.00	19.00	European Environmental Bureau (2020)
	ENV-5	Logical	0.414	0.105	0.125	0.111	0.086	0.136	0.024	Mastrocinque et al. (2020)
	ENV-6	Logical	0.378	0.075	0.129	0.094	0.174	0.118	0.032	Mastrocinque et al. (2020)

Table 3
Fuzzy Inference Systems computed outputs for each country.

Clusters	Germany	Italy	UK	France	Spain	Belgium	Greece
Internal	0.8687	0.181	0.8469	0.5237	0.33	0.8661	0.1574
External	0.8516	0.5	0.5	0.1405	0.5	0.5	0.5
Revenues	0.5	0.1725	0.1419	0.5	0.8322	0.5	0.1623
Costs	0.5	0.7262	0.3391	0.1734	0.3498	0.1395	0.8566
Financing	0.87	0.1695	0.6264	0.8491	0.5	0.8431	0.13
Compliance	0.7183	0.5	0.5	0.13	0.1547	0.5	0.8618
Prevention	0.87	0.1525	0.169	0.1553	0.2805	0.5	0.13
TBL pillars							
Social	0.8926	0.35	0.65	0.35	0.4183	0.65	0.35
Economic	0.5	0.5	0.4357	0.5	0.5	0.5	0.5
Environmental	0.8725	0.35	0.35	0.1082	0.1264	0.5	0.5

- Big data and data analytics are the technology with the greatest impact on the overall PV-SSC, followed by cloud technologies, mobile services and artificial intelligence. Meanwhile, 3D printing and robotic and automated machinery are the technologies with the lowest impact.
- Analysing the results for each TBL pillar, the outcomes again reveal that big data and data analytics are the technology with the greatest impact on the three pillars (social, economic and environmental), followed by mobile services in the social pillar, and cloud technologies in the economic and environmental pillars. The lowest impact corresponds to 3D printing for the social and economic pillars, and cybersecurity solutions for the environmental pillar.
- The results of the analysis for each level of the PV-SSC show big data and data analytics as the I4.0 key technology with the greatest

impact on the supply, generation, demand and disposal levels, whereas cloud technologies has the greatest influence along the distribution level. In contrast, robotic and automated machinery is the technology with the lowest impact on the supply and demand levels, whereas 3D printing has the lowest influence on generation, distribution and disposal levels.

Four different scenarios based on different values of the weights in Eq. 1, shown in Table 4, were then investigated. Equal importance was given to the three sustainability pillars in Scenario 1; in Scenario 2, twice the importance was given to the social pillar compared to the other two pillars; twice the importance was given to the economic pillar in Scenario 3; finally twice importance was given to environmental pillar in Scenario 4.

Moreover, the Digital Transformation Enablers Index for each considered country were extracted from Probst et al. (2018) and shown in Table 5. Finally, *SOCl*, *ECOI*, *ENVI* and *I4II_{SOC}*, *I4II_{Eco}*, *I4II_{ENV}* were normalised between 0 and 1, and the Sustainability Index 4.0 for each country, in each scenario, was calculated and shown in Fig. 8.

The analysis of the results and the outcomes shown in Table 3 identify areas of improvement regarding the clusters, criteria and impact of I4.0 enablers to increase the value of the SI4.0 for each country. It is thus suggested that each country should adopt the most appropriate measures to improve their scores on the identified clusters and criteria.

In the same way, analysis of the results concerning the SI4.0 score for the seven countries under study and the four considered scenarios, as shown in Fig. 8, reveals that Belgium presents the highest SI4.0 in Scenario 1, 2 and 4, while France has the highest in Scenario 3. Meanwhile, Greece exhibits the lowest value in Scenario 1, 2 and 3, while Spain does so in Scenario 4. In this way, results unveil several areas of improvement for the countries with lower SI4.0 scores considering the impact of the I4.0 enablers along the different levels of the PV-SSC, as follows:

- Analysing Scenario 1, in which the weights of the TBL pillars are balanced, Italy and Greece present the lower scores. Based on the previous analysis of clusters and factors, and the analysis of the four experts shown in Fig. 7, Italy and Greece could improve their SI4.0 score by enhancing the Social-internal and Environmental-prevention clusters. Considering the Social-internal cluster, the improvement could be made by using big data and data analytics, mobile devices and cloud technologies in the Supply stage; artificial intelligence and cybersecurity solutions in the Generation stage; mobile services, big data and data analysis, cybersecurity solutions and social media in the Distribution stage; and cloud technologies in the Disposal stage. In the same way, France could enhance the Social external cluster by the use of big data and data analytics, mobile services and cloud technologies in the Supply stage; big data and data analytics in the Generation stage; mobile services, cybersecurity solutions, cloud technologies and artificial intelligence in the Distribution stage; and big data and data analytics, mobile services and artificial intelligence in the Demand and Disposal stages. In the same way, these countries could improve SI4.0 by actions to enhance the Environmental-prevention cluster, and more specifically by the use of cloud technologies, big data and data analytics, and mobile services in the Distribution stage; and big data and data analytics and cloud technologies in the Disposal stage.

Table 4
Values of weights for each scenario.

	wSoc	wEco	wEnv
Scenario 1	0.33	0.33	0.33
Scenario 2	0.5	0.25	0.25
Scenario 3	0.25	0.5	0.25
Scenario 4	0.25	0.25	0.5

Table 5
Digital Transformation Enablers Index for each country (Probst et al., 2018).

	Germany	Italy	UK	France	Spain	Belgium	Greece
DTEI	0.599	0.406	0.621	0.616	0.564	0.737	0.36

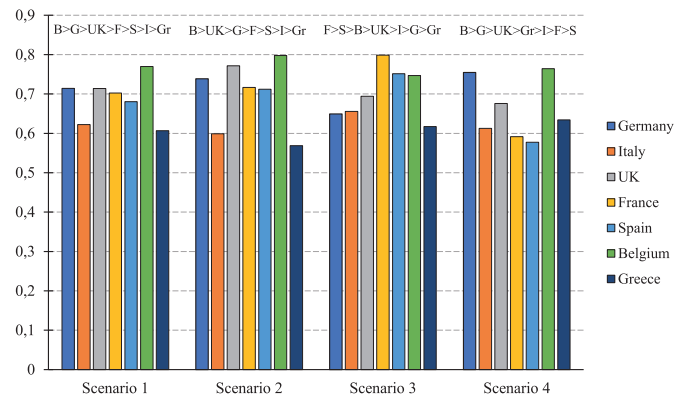

Fig. 8. Sustainability Index 4.0 (SI4.0) computed values for each country and scenario.

- A similar analysis could be conducted for Scenario 2, in which the lowest scores are also those for Italy and Greece.
- Concerning the outcomes for Scenario 3, in which greater weight is assigned to the economic pillar, Germany is located in the lower SI4.0 scores, together with Italy and Greece. In this sense, Germany's SI4.0 score could be enhanced by improving of the Economic-revenues and Economic-costs clusters. To do so, Germany could improve the use of big data and data analytics along the complete PV-SSC; the IoT and cloud technologies in the Supply and Generation stages; social media and the IoT in the Distribution and Demand stages; and artificial intelligence in the Disposal stage.

Finally, analysing the results for Scenario 4, with a higher weight for the Environmental pillar, the country with the lower SI4.0 score is Spain, followed by France and Italy. In order to improve the SI4.0 index, Spain must improve both the Environmental-compliance and Environmental-prevention clusters. To do it, this country must encourage the use of big data and data analysis in the Generation and Demand stages, cloud technologies in the Distribution stage, and a combination of IoT with cloud technologies and big data and data analysis in the Disposal stage.

5.5. Managerial implications

The proposed multi-criteria approach and results have significant managerial implications. Firstly, we provide decision-makers with the main factors and clusters to take into account to design and assess a PV supply chain according to TBL and considering the impact of I4.0 and digital technologies. Moreover, the selected criteria have been linked to the different stages in the PV supply chain and the impact of the main I4.0 technologies have been linked to the considered criteria and stages in the SC. Secondly, the use of Fuzzy logic and the definition of the Sustainability Index 4.0 will provide decision-makers with a fast and easy tool for solving such a complex decision problem. The proposed approach will allow decision-makers not only to assess, but also to identify a specific country or location for developing a SSC in the PV sector considering its digital technology enabling conditions. Moreover, the approach will help decision makers to explore different scenarios based on the importance given to the three TBL dimensions. For example, prioritising one sustainability target over another according to new regulations imposed by the governments. Finally, the proposed approach will allow areas of improvement to be identified, such as

factors, clusters, I4.0 impact and country readiness for increasing the overall Sustainability Index 4.0. In this sense, the proposed methodology enables, on the one hand, a diagnosis of the TBL clusters identifying the criteria with the highest and lowest influence on supply chain performance and, on the other hand, the identification of the I4.0 enablers that allow for the enhancement of the sustainability pillars in each level of the supply chain. In this way, the Sustainability Index 4.0 for a specific country could be improved by encouraging measures to increase the adoption and use of the most appropriate I4.0 enablers for each stage of the supply chain.

6. Conclusions and future research opportunities

This paper proposes a multi-criteria intelligent approach using fuzzy logic, quantitative data and experts' opinions to calculate the Sustainability Index 4.0 of a SSC in the PV sector considering the impact of I4.0 and digital technologies. Following the TBL, social, economic and environmental factors were taken into account as the main dimensions. After a thorough literature review, the main stages of the PV supply chain and the criteria affecting the main three sustainability pillars were identified. Subsequently, the criteria were clustered and three Fuzzy Inference Systems were designed to calculate an index for each TBL pillar. Four experts in the PV sector were asked to assess the impact of I4.0 and digital technologies on the sustainability criteria in each stage of the PV-SSC. Finally, a Sustainability Index 4.0 was defined and calculated for seven European countries taking into account the Digital Technologies Enabling Index, as well as different scenarios according to the importance given to each TBL pillar.

The results show the potential of the proposed approach for developing a sustainable supply chain for PV energy production, and it is the first to take into account the impact of I4.0 and digital technologies on the sustainability criteria for each stage of the SC. Furthermore, the results allow identifying areas of improvement in terms of I4.0 enablers and TBL criteria, to increase the overall sustainability across the PVSC.

Appendix A. Description and justification of criteria on the TBL dimensions

A.1. Social criteria

A.1.1. Internal

- Employment and job opportunities (SOC-1) measures the number of labour places in the sector, per year and million inhabitants, in the country. Different authors have used this criterion to quantify internal social impacts on the SC (Govindan et al., 2013; Mastrocinque et al., 2020; You et al., 2012). The indicator is assessed from data reported by international energy agencies (IEA, 2019a,b,c,d,e; IRENA, 2018). Considering the growth of employment is beneficial for the country, this is a criterion to maximise.
- Wage level (SOC-2) is a significant factor in assessing the social impact of sustainability (Yakovleva et al., 2012). It is taken as the lowest wage that employers are legally obliged to pay their employees. This is the basic national minimum wage enforced by law that each government fixes at an hourly, weekly or monthly rate, and often after consultation with social partners, or directly by national intersectorial agreement (this is the case for Belgium and Greece). In this research, the values to assess this criterion have been obtained from Eurostat (2020b), the statistics office of the European Commission (EC), and valued in €/month in each country. This is an indicator to maximise.
- Gender employment gap (SOC-3) is another standard indicator in the assessment of sustainability [2012]. It measures the difference between the employment rates of men and women of working age. In this research, the employment rate is calculated by dividing the number of persons in employment, aged from 20 to 64, by the total population of the same age group. The indicator is based on the EU Labour Force Survey conducted by [2019a]. It is a criterion to minimise.

A.1.2. External

- Stakeholder influence (SOC-4) refers to the companies' relationship with the different players they interact along the SC: customers, consumers, suppliers, local communities, and governmental and non-governmental organisations. It is a typical criterion in research works assessing the sustainability dimensions in the SC domain (Ahi and Searcy, 2013; Govindan et al., 2013; Mastrocinque et al., 2020; Seuring, 2013). Due to the difficulty in assessing stakeholder influence using information and data from the literature, this criterion is measured in qualitative terms, using linguistic labels, and based on the experts' opinions recorded by the authors in recent research (see Mastrocinque et al. (2020)), being a criterion to maximise.

The proposed approach can be applied to investigate other countries or regions, as well as exploring different scenarios in terms of the importance given to each TBL pillar. Moreover, it can be modified and adapted to consider alternative RE sources, such as wind power. Furthermore, the proposed approach can be generalised and applied to other sectors by selecting appropriate sustainability criteria and clusters. Other future research directions may consider developing optimisation models addressing decisions such as location, supplier selection, technology selection, logistics modes and recycling options, with the aim of designing sustainable supply chains in the context of I4.0. Finally, there is a need for more empirical studies and quantitative research approaches to investigate the possible impact of I4.0 and digital technologies on enabling sustainability and sustainable supply chain development.

CRedit authorship contribution statement

Ernesto Mastrocinque: Conceptualisation, Methodology, Software, Formal analysis, Investigation, Resources, Writing - Original Draft, Writing - Review & Editing, Supervision, Project administration.

F. Javier Ramírez: Conceptualisation, Validation, Formal analysis, Investigation, Resources, Data Curation, Writing - Original Draft, Writing - Review & Editing, Project administration.

Andres Honrubia-Escribano: Validation, Investigation, Resources, Writing - Original Draft, Visualization.

Duc T Pham: Supervision.

Acknowledgments

This research was partially funded by MCIN/AEI/10.13039/501100011033 with Grant PID2020-117398GB-I00 (Government of Spain). The authors would also like to thank the four experts for their valuable contribution to the research work.

- Social acceptability (SOC-5) of the PV sector at country level is not easy to evaluate. Recent research assessing the acceptance of technologies for production of renewable energy reveals the importance of attitudes in influencing social acceptance in PV. Moreover, barriers, legal impediments and public opposition exist that prevent the deployment of PV plants in some countries, such as in the UK. Other studies present social acceptance as a multidimensional problem, where socio-political, community and market factors must be balanced and tallied with the investors and users' interests in embracing PV projects. Taking into account all these aspects, social acceptability is measured in this research as the PV market penetration at country level (IEA, 2019f), understanding that countries that have fostered PV plants are those with better acceptability in global terms. It is a criterion to maximise.
- Population growth (SOC-6) is a specific social aspect in quantitative models assessing SSCM (Brandenburg et al., 2014), due to people enjoying the improvement in the standard of living generated by industrialisation and deployment of clean technologies. Population growth in the selected countries is assessed with information from the EC (Eurostat, 2018), being a criterion to maximise.

A.2. Economic criteria

A.2.1. Revenues

- Feed-in-tariffs (ECO-1). This is one of the main support policies used in EU countries to stimulate the installation of PV power plants. Under this scheme, the producer receives a fixed payment per kWh of generated electricity with a specified price. In addition, this payment is guaranteed by the government for between 20 and 25 years (Ramírez et al., 2017). Thus, we consider as an economic criterion due to this support scheme having been essential in PV energy adoption in most European countries. The data were obtained from the information provided by international energy agencies (IEA, 2019f; PVTECH, 2020), and measured in €/kWh. It is a criterion to maximise.
- R&D governmental support (ECO-2). This is a subsidy scheme focused on developing new PV plants to stimulate the market. It is an economic criterion typically used to make decisions about plant location (Mota et al., 2015) due to the relationship between government financial support and the location of the PV plant. In this research, it is a criterion measured in €per year and million inhabitants in the corresponding country, being a criterion to maximise.
- Energy sales (ECO-3) depend on the PV plant location and the electricity spot price at which the generated energy is sold. The PV plant location largely determines the yearly production of electricity on the site, so the energy yield is a key factor in making decisions on plant location and a common indicator in the estimation of energy production in PV facility projects. To assess energy yield in each analysed country, this work uses the data provided by the Photovoltaic Geographical Information System (PVGIS) (European Commission, 2021). Additionally, the electricity spot price in force for each selected country is determined with data provided by Eurostat (2020a,b,c,d). Values of energy sales are measured in kWh/kW_{p-year}. It is a criterion to maximise.

A.2.2. Costs

- Sourcing costs (ECO-4) include the costs of all the raw materials and commodities, acquired in the country or in foreign countries involved in building the PV plant. Of these, PV panels and inverters are the most expensive components, representing the largest part of the investment. Sourcing costs have been greatly reduced in recent years (Ramírez et al., 2017) favoured by the research in new materials (PV panels) and the reduction in tariffs and governmental incentives putting pressure on manufacturers and installers to lower the price per kilowatt for new PV projects. This work uses updated information provided by the International Energy Agency (IEA, 2019f) to select the sourcing costs in each analysed country. Data are provided in €/W_p being a criterion to minimise.
- Upfront costs (ECO-5) refer to the total investment at the initial stage of a PV plant, including all the sourcing costs (see ECO-4 criterion) and non-sourcing costs, such as mounting hardware, installation labour, fees, shipping, overhead company costs, and taxes. Data used in this research are provided by different international energy agencies (IEA, 2019a,b,c,d,e; IRENA, 2019; Psomas, 2018). Values are provided in €/W_p. It is a criterion to minimise.
- Operation and maintenance (O&M) costs (ECO-6). This criterion refers to different costs associated with several operations that are mandatory to complete and operate the PV plant, including electrical maintenance, panel washing, vegetation control, insurances, general site management, and others. These costs are not significant in PV plants compared to their upfront costs, so it is usual to value them as a fixed term per kilowatt of installed power. Values are adopted from previous works (Mastrocinque et al., 2020; Ramírez et al., 2017) and measured in €/kW for each selected country. It is a criterion to minimise.

A.2.3. Financing

- Cost of capital (ECO-7), taken as the weighted average cost of capital (WACC), refers to the rate of return that an investor (a country in our research) expects considering the best investment alternative with equivalent risk. It is an indicator commonly used to compare the profitability of the PV project. If the profitability of the project is higher than the WACC, the project is feasible. In this research, cost of capital has been selected by country, with data provided by the work of Mastrocinque et al. [2020], being an indicator to minimise.
- Country Risk Premium (ECO-8) is the additional return demanded by the investors in order to compensate the higher risk of investing in a foreign country/market as compared with investing in the domestic country/market. It is a significant indicator the investor assesses in order to make investment decisions being a measure of the risk associated with investing in a determined country. In our research, data are provided by Expansion [2020] and it is a criterion to minimise.
- Long-Term government bond yield 10-year (ECO-9) refers to the central government bond yield on the secondary market, taxes included, with a residual maturity of around 10 years. It is a measure of the price the country pays for its long term debt and is an indicator of the risk of investing in

a particular country. In this research, data for the selected countries are provided by the European Central Bank (ECB), available in [Eurostat \(2020a\)](#). It is a criterion to minimise.

A.3. Environmental criteria

A.3.1. Compliance

- Renewable energy target share gap (ENV-1). Directive 2009/28/EC ([European Commission, 2009](#)) promotes the use of energy from renewable sources (RES) as a key element in energy policy, and establishes accounting criteria to reach the proposed 2020 targets for renewable energy sources in the EU member states. RES include wind power, solar power (thermal, photovoltaic and concentrated), hydro power, tidal power, geothermal energy, ambient heat captured by heat pumps, biofuels and the renewable part of waste. In our research, the RE target share gap in each selected country is calculated as difference between the RE 2020 target in the country and the harmonised calculation of the share of energy from renewable sources provided by the SHARES tool ([Eurostat, 2020c](#)). It is a criterion to minimise.
- PV share (ENV-2) refers to the quota of generated electricity from PV in relation to the total gross final consumption of electricity from RES. Data are obtained by means of the SHARES tool ([Eurostat, 2020c](#)), being a criterion to maximise.
- GHG emissions reduction (ENV-3). The EU 2020 Climate and Energy Package (available in [European Commission \(2020\)](#)) and decision No 406/2009/EC of the [European Parliament and the Council \(2009\)](#), introduced a clear approach to achieving a 20 % reduction in total GHG emissions, compared with 1990 levels, as one of three key climate and energy targets, together with 20 % of EU energy from renewables and 20 % in improvement of energy efficiency. In this research, it is a criterion analysing the reduction of CO₂, NO_x and SO₂ gas emissions in a certain period thanks to the use of clean technologies like PV, recognised as a zero emissions technology. Data were obtained from the European Environment Agency ([EEA, 2020](#)), being a criterion to maximise.

A.3.2. Prevention

- Recycling rate (ENV-4). European Union has promoted initiatives and laws ([European Parliament, 2018](#)) to bolster waste recycling, with the adoption of specific targets, with Member States being required to recycle at least 55 % of their municipal waste by 2025, 60 % by 2030, and 65 % by 2035. Recommendations include economic incentives for reuse and the phase-out of subsidies promoting waste. In our research, the recycling rate is assessed in the selected countries using the information provided by the [European Environmental Bureau \(2020\)](#), being a criterion to maximise.
- Green disposal policies (ENV-5) concerns the legislative initiatives and laws implemented to comply with the Directive 2012/19/EU ([European Parliament, 2012](#)) adopted by EU countries to protect the environment and human health. These initiatives focus on the reduction of adverse impacts of waste from electrical and electronic equipment (WEEE), reducing the overall impacts of the fast increasing waste stream. In this research, this criterion was assessed by the experts' opinions (see [Mastrocinque et al. \(2020\)](#)) using a qualitative scale. It is a criterion to maximise.
- Technology for disposal (ENV-6) refers to the recovery modes for disposing of the PV panels at the end-of-life, including the reuse, remanufacturing and recycling of specific parts and achieving the greatest economic feasibility of these works. Recycling and disposal technologies of PV panels have been widely explored in recent years ([Hsu and Kuo, 2020](#)) with some of them being economically viable. This is a criterion to be maximised and assessed by means of experts' opinions in the previous work by [Mastrocinque et al. \(2020\)](#).

Appendix B. Rules defined for a 3-inputs Fuzzy Inference Systems such as ECO1–3

- If Feed-in-tariffs is Low and R&D governmental support is Low and Energy sales is Low then Revenues is Low.
- If Feed-in-tariffs is Low and R&D governmental support is Low and Energy sales is Medium then Revenues is Low.
- If Feed-in-tariffs is Low and R&D governmental support is Low and Energy sales is High then Revenues is Medium.
- If Feed-in-tariffs is Low and R&D governmental support is Medium and Energy sales is Low then Revenues is Low.
- If Feed-in-tariffs is Low and R&D governmental support is Medium and Energy sales is Medium then Revenues is Medium.
- If Feed-in-tariffs is Low and R&D governmental support is Medium and Energy sales is High then Revenues is Medium.
- If Feed-in-tariffs is Low and R&D governmental support is High and Energy sales is Low then Revenues is Medium.
- If Feed-in-tariffs is Low and R&D governmental support is High and Energy sales is Medium then Revenues is Medium.
- If Feed-in-tariffs is Low and R&D governmental support is High and Energy sales is High then Revenues is High.
- If Feed-in-tariffs is Medium and R&D governmental support is Low and Energy sales is Low then Revenues is Low.
- If Feed-in-tariffs is Medium and R&D governmental support is Low and Energy sales is Medium then Revenues is Medium.
- If Feed-in-tariffs is Medium and R&D governmental support is Low and Energy sales is High then Revenues is Medium.
- If Feed-in-tariffs is Medium and R&D governmental support is Medium and Energy sales is Low then Revenues is Medium.
- If Feed-in-tariffs is Medium and R&D governmental support is Medium and Energy sales is Medium then Revenues is Medium.
- If Feed-in-tariffs is Medium and R&D governmental support is Medium and Energy sales is High then Revenues is Medium.
- If Feed-in-tariffs is Medium and R&D governmental support is High and Energy sales is Low then Revenues is Medium.
- If Feed-in-tariffs is Medium and R&D governmental support is High and Energy sales is Medium then Revenues is Medium.
- If Feed-in-tariffs is Medium and R&D governmental support is High and Energy sales is High then Revenues is High.
- If Feed-in-tariffs is High and R&D governmental support is Low and Energy sales is Low then Revenues is Medium.
- If Feed-in-tariffs is High and R&D governmental support is Low and Energy sales is Medium then Revenues is Medium.
- If Feed-in-tariffs is High and R&D governmental support is Low and Energy sales is High then Revenues is Medium.
- If Feed-in-tariffs is High and R&D governmental support is Medium and Energy sales is Low then Revenues is Medium.

If Feed-in-tariffs is High and R&D governmental support is Medium and Energy sales is Medium then Revenues is Medium.
 If Feed-in-tariffs is High and R&D governmental support is Medium and Energy sales is High then Revenues is High.
 If Feed-in-tariffs is High and R&D governmental support is High and Energy sales is Low then Revenues is Medium.
 If Feed-in-tariffs is High and R&D governmental support is High and Energy sales is Medium then Revenues is High.
 If Feed-in-tariffs is High and R&D governmental support is High and Energy sales is High then Revenues is High.

Appendix C. Acronyms

Abbreviation	Definition
AHP	Analytic Hierarchy Process
ANP	Analytical Network Process
AI	Artificial intelligence
BOCR	Benefit, Opportunity, Cost, Risk
CSR	Corporate social responsibility
DEA	Data envelopment analysis
DEMATEL	Decision Making Trial and Evaluation Laboratory
DTS	Digital Transformation Scoreboard
ELECTRE	ELimination and Choice Translating REality
EU	European Union
FiT	Feed-in Tariff
GHG	Green House Gas
GW	Gigawatt
IEA	International Energy Agency
IT	information technology
IoT	Internet of Things
I4.0	Industry 4.0
MCDM	Multi-criteria decision making
MILP	Mixed integer linear programming
MS-FGP	Multi-segment fuzzy goal programming
O&M	Operation and maintenance
PV	Photovoltaic
PVGIS	Photovoltaic Geographical Information System
PVSC	Photovoltaic supply chain
PV-SSC	Photovoltaic sustainable supply chain
RE	Renewable energy
RES	Renewable energy sources
SC	Supply chain
SI4.0	Sustainability Index 4.0
SSC	Sustainable supply chain
SSCM	Sustainable Supply Chain Management
TBL	Triple Bottom Line
TOPSIS	Technique to Order Preference by Similarity to Ideal Solution
VPP	Virtual power plant

References

- Ageron, B., Gunasekaran, A., Spalanzani, A., 2012. Sustainable supply management: an empirical study. *Int. J. Prod. Econ.* 140, 168–182.
- Ahi, P., Searcy, C., 2013. A comparative literature analysis of definitions for green and sustainable supply chain management. *J. Clean. Prod.* 52, 329–341.
- Ahmad, S., Tahar, R.M., 2014. Selection of renewable energy sources for sustainable development of electricity generation system using analytic hierarchy process: a case of Malaysia. *Renew. Energy* 63, 458–466.
- Ali, Z., Mahmood, T., Ullah, K., Khan, Q., 2021. Einstein geometric aggregation operators using a novel complex interval-valued pythagorean fuzzy setting with application in green supplier chain management. *Rep. Mech. Eng.* 2, 105–134.
- Alizadeh, R., Soltanisehat, L., Lund, P.D., Zamanisabzi, H., 2020. Improving renewable energy policy planning and decision-making through a hybrid mcdm method. *Energy Policy* 137, 111174.
- Bag, S., Telukdarie, A., Pretorius, J., Gupta, S., 2021. Industry 4.0 and supply chain sustainability: framework and future research directions. *Benchmarking: An International Journal* 28 (5), 1410–1450. <https://doi.org/10.1108/BLJ-03-2018-0056>.
- Balaman, Ş.Y., Selim, H., 2016. Sustainable design of renewable energy supply chains integrated with district heating systems: a fuzzy optimization approach. *J. Clean. Prod.* 133, 863–885.
- Birkel, H.S., Müller, J.M., 2021. Potentials of industry 4.0 for supply chain management within the triple bottom line of sustainability—a systematic literature review. *J. Clean. Prod.* 125612.
- Bonilla, S.H., Silva, H.R., Terra da Silva, M., Franco Gonçalves, R., Sacomano, J.B., 2018. Industry 4.0 and sustainability implications: a scenario-based analysis of the impacts and challenges. *Sustainability* 10, 3740.
- Brandenburg, M., Rebs, T., 2015. Sustainable supply chain management: a modeling perspective. *Ann. Oper. Res.* 229, 213–252.
- Brandenburg, M., Govindan, K., Sarkis, J., Seuring, S., 2014. Quantitative models for sustainable supply chain management: developments and directions. *Eur. J. Oper. Res.* 233, 299–312.
- Büyükoçkan, G., Güleriyüz, S., 2017. Evaluation of renewable energy resources in Turkey using an integrated mcdm approach with linguistic interval fuzzy preference relations. *Energy* 123, 149–163.
- Caiado, R.G.G., Scavarda, L.F., Gavião, L.O., Ivson, P., de Mattos Nascimento, D.L., Garza-Reyes, J.A., 2021. A fuzzy rule-based industry 4.0 maturity model for operations and supply chain management. *Int. J. Prod. Econ.* 231, 107883.
- Chen, M., Sinha, A., Hu, K., Shah, M.I., 2021. Impact of technological innovation on energy efficiency in industry 4.0 era: moderation of shadow economy in sustainable development. *Technol. Forecast. Soc. Chang.* 164, 120521.
- Chen, Z., Su, S.I.I., 2018. Multiple competing photovoltaic supply chains: modeling, analyses and policies. *J. Clean. Prod.* 174, 1274–1287.
- Çolak, M., Kaya, İ., 2017. Prioritization of renewable energy alternatives by using an integrated fuzzy mcdm model: a real case application for Turkey. *Renew. Sust. Energy Rev.* 80, 840–853.
- Darbari, J.D., Kannan, D., Agarwal, V., Jha, P., 2019. Fuzzy criteria programming approach for optimizing the tbl performance of closed loop supply chain network design problem. *Ann. Oper. Res.* 273, 693–738.
- Dehghani, E., Jabalameli, M.S., Jabbarzadeh, A., 2018. Robust design and optimization of solar photovoltaic supply chain in an uncertain environment. *Energy* 142, 139–156.
- Dehghani, E., Jabalameli, M.S., Naderi, M.J., Safari, A., 2020. An environmentally conscious photovoltaic supply chain network design under correlated uncertainty: a case study in Iran. *J. Clean. Prod.* 262, 121434.
- Dogaru, L., 2020. The main goals of the fourth industrial revolution. *Renewable energy perspectives. Procedia Manuf.* 46, 397–401.
- Duarte, S., Cruz-Machado, V., 2017. Exploring linkages between lean and green supply chain and the industry 4.0. In: *International Conference on Management Science and Engineering Management*. Springer, pp. 1242–1252.

- Dubey, R., Gunasekaran, A., Papadopoulos, T., Childe, S.J., Shibin, K., Wamba, S.F., 2017. Sustainable supply chain management: framework and further research directions. *J. Clean. Prod.* 142, 1119–1130.
- EEA, 2020. Member States' greenhouse gas (GHG) emission projections. Technical report. URL: European Environment Agency <https://www.eea.europa.eu/data-and-maps/data/greenhouse-gas-emission-projections-for-6>. (Accessed 21 May 2015).
- Elkington, J., 1997. Cannibals with forks. In: *The Triple Bottom Line of 21st Century*, pp. 1–16.
- European Commission, 2009. Directive 2009/28/EC of the European Parliament and of the Council of 23 April 2009. Technical Report 16. European Commission.
- European Commission, 2012. The International Reference Life Cycle Data System (ILCD) Handbook. Technical Report. European Commission. <https://doi.org/10.2788/85727>.
- European Commission, 2016. Overview of European initiatives on digitising industry. Technical report. URL: European Union (accessed:21.01.31). http://ec.europa.eu/information_society/newsroom/image/document/2016-16/overview_of_digitising_industry_with_links_15202.pdf.
- European Commission, 2018. Digital transformation scoreboard 2018. EU business go digital: opportunities, outcomes and uptake. Technical report. URL: European Union (accessed:21.07.20). <https://ec.europa.eu/growth/tools-databases/dem/monitor/scoreboard>.
- European Commission, 2020. 2020 climate & energy package. Technical report. URL: European Commission https://ec.europa.eu/clima/policies/strategies/2020_en. (Accessed 21 May 2015).
- European Commission, 2021. Photovoltaic Geographical Information System (PVGIS). Technical report. URL: European Commission. Joint Research Centre. Institute for Energy (accessed:21.04.29). <http://re.jrc.ec.europa.eu/pvgis/>.
- European Environmental Bureau, 2020. Waste no more: introducing Europe's new waste laws. Technical report. URL: European Environmental Bureau <https://eeb.org/waste-no-more-introducing-europes-new-waste-laws/>. (Accessed 21 May 2014).
- European Parliament, 2012. Directive 2012/19/EU of the European Parliament and of the Council on Waste Electrical and Electronic Equipment (WEEE). Technical Report. European Commission.
- European Parliament, 2018. Circular economy: MEPs back plans to boost recycling and cut landfilling. Technical report. URL: European Union (accessed:21.05.14). <https://www.europarl.europa.eu/news/en/press-room/20180227IPR98710/circular-economy-meps-back-plans-to-boost-recycling-and-cut-landfilling>.
- European Parliament and the Council, 2009. Decision No 406/2009/EC of the European Parliament and of the Council of 2009 on the Effort of Member States to Reduce Their Greenhouse Gas Emissions to Meet the Community's Greenhouse Gas Emission Reduction Commitments up to 2020. Technical Report. European Union.
- Eurostat, 2018. Population and population change statistics. Technical report. European Commission. URL: https://ec.europa.eu/eurostat/statistics-explained/index.php/Population_and_population_change_statistics#EU-28_population_continues_to_grow (accessed:21.04.23).
- Eurostat, 2019a. Gender employment gap. Technical report. URL: European Commission (accessed:21.04.22). https://ec.europa.eu/eurostat/web/products-datasets/product?code=sdg_05_30_.
- Eurostat, 2019b. Renewable energy statistics. Technical report. URL: European Commission (accessed:21.04.24). <https://ec.europa.eu/eurostat/statistics-explained/>.
- Eurostat, 2020. Energy Price Statistics. Technical Report. European Commission. URL: http://ec.europa.eu/eurostat/statistics-explained/index.php/Electricity_price_statistics (accessed:21.05.13).
- Eurostat, 2020a. Long term government bond yields. Technical report. URL: European Commission (accessed:21.02.01). <https://ec.europa.eu/eurostat/databrowser/view/teimf050/default/table?lang=en>.
- Eurostat, 2020b. Minimum wage statistics. Technical report. URL: European Commission (accessed:21.04.21).
- Eurostat, 2020c. SHARES tool. Harmonised calculation of the share of energy from renewable sources. Technical report. URL: European Commission (accessed: 21.05.05). <https://ec.europa.eu/eurostat/web/energy/data/shares>.
- Expansion, 2020. Macroeconomic data. Technical report. URL: Unidad Editorial Información Económica S.L (accessed:21.03.24). <https://datosmacro.expansion.com/paises/>.
- Fazlollahabbar, H., Kazemitash, N., 2021. Green Supplier Selection Based on the Information System Performance Evaluation Using the Integrated Best-worst Method. In: *Series: Mechanical Engineering*. Facta Universitatis.
- Furstenau, L.B., Sott, M.K., Kipper, L.M., Machado, E.L., López-robles, J.R., Dohan, M.S., Cobo, M.J., Zahid, A., Abbasi, Q.H., Imran, M.A., 2020. Link between sustainability and industry 4.0: trends, challenges and new perspectives. *IEEE Access* 8, 140079–140096.
- Genovese, A., Acquaye, A.A., Figueroa, A., Koh, S.L., 2017. Sustainable supply chain management and the transition towards a circular economy: evidence and some applications. *Omega* 66, 344–357.
- Ghobakhloo, M., 2020. Industry 4.0, digitization, and opportunities for sustainability. *J. Clean. Prod.* 252, 119869.
- Govindan, K., Hasanagic, M., 2018. A systematic review on drivers, barriers, and practices towards circular economy: a supply chain perspective. *Int. J. Prod. Res.* 56, 278–311.
- Govindan, K., Khodaverdi, R., Jafarian, A., 2013. A fuzzy multi criteria approach for measuring sustainability performance of a supplier based on triple bottom line approach. *J. Clean. Prod.* 47, 345–354.
- GRI, 2013. G4 Sustainability Reporting Guidelines. Global Reporting Initiative, Amsterdam, Netherlands.
- Gunasekaran, A., et al., 2004. Supply chain management: theory and applications. *Eur. J. Oper. Res.* 159, 265–268.
- Hassini, E., Surti, C., Searcy, C., 2012. A literature review and a case study of sustainable supply chains with a focus on metrics. *Int. J. Prod. Econ.* 140, 69–82.
- Herrmann, C., Schmidt, C., Kurle, D., Blume, S., Thiede, S., 2014. Sustainability in manufacturing and factories of the future. *Int. J. Precis. Eng. Manuf. Green Technol.* 1, 283–292.
- Hidayatno, A., Destyanto, A.R., Hulu, C.A., 2019. Industry 4.0 technology implementation impact to industrial sustainable energy in Indonesia: a model conceptualization. *Energy Procedia* 156, 227–233.
- Hocine, A., Kouaissah, N., Bettahar, S., Benbouziane, M., 2018. Optimizing renewable energy portfolios under uncertainty: a multi-segment fuzzy goal programming approach. *Renew. Energy* 129, 540–552.
- Hsu, E., Kuo, C.M., 2020. A recycling system for sustainable management of waste solar photovoltaic panels in Taiwan. In: *Energy Technology 2020: Recycling, Carbon Dioxide Management, and Other Technologies*. Springer, pp. 241–248.
- IEA, 2019a. National Survey Report of PV Power Applications in Belgium. Technical Report. International Energy Agency.
- IEA, 2019b. National Survey Report of PV Power Applications in France. Technical Report. International Energy Agency.
- IEA, 2019c. National Survey Report of PV Power Applications in Germany. Technical Report. International Energy Agency.
- IEA, 2019d. National Survey Report of PV Power Applications in Italy. Technical Report. International Energy Agency.
- IEA, 2019e. National survey report of PV power applications in Spain. Technical Report. International Energy Agency.
- IEA, 2019f. Trends in photovoltaic applications 2019. Report IEA PVPS T1-36. Technical report. URL: International Energy Agency (accessed:21.04.30). <https://resources.solarbusinesshub.com/item/pvps-report-trends-in-photovoltaic-applications-2019/>.
- IEA, 2020. Trends in photovoltaic applications 2020. Technical report. URL: International Energy Agency <https://iea-pvps.org/trends-reports/trends-in-pv-applications-2020/>. (Accessed 21 February 2018).
- International Energy Agency, 2020. Snapshot of Global PV Markets 2020. Technical Report. International Energy Agency.
- IRENA, 2018. Renewable Energy and Jobs. Annual Review 2018. Technical Report. International Renewable Energy Agency.
- IRENA, 2019. Renewable Power Generation Costs in 2018. Technical Report. International Renewable Energy Agency, Abu Dhabi.
- Kang, H.S., Lee, J.Y., Choi, S., Kim, H., Park, J.H., Son, J.Y., Kim, B.H., Do Noh, S., 2016. Smart manufacturing: past research, present findings, and future directions. *Int. J. Precis. Eng. Manuf. Green Technol.* 3, 111–128.
- Kazemitash, N., Fazlollahabbar, H., Abbaspour, M., 2021. Rough best-worst method for supplier selection in biofuel companies based on green criteria. *Oper. Res. Eng. Sci. Theory Appl.* 4, 1–12.
- Kenzhina, M., Kalysh, I., Ukaegbu, I., Nunna, S.K., 2019. Virtual power plant in industry 4.0: the strategic planning of emerging virtual power plant in Kazakhstan. In: *21st International Conference on Advanced Communication Technology (ICACT)*, pp. 600–605.
- Kumar, A., Sah, B., Singh, A.R., Deng, Y., He, X., Kumar, P., Bansal, R., 2017. A review of multi criteria decision making (mcdm) towards sustainable renewable energy development. *Renew. Sust. Energ.* 69, 596–609.
- Li, G., Hou, Y., Wu, A., 2017. Fourth industrial revolution: technological drivers, impacts and coping methods. *Chin. Geogr. Sci.* 27, 626–637.
- Luthra, S., Mangla, S.K., 2018. Evaluating challenges to industry 4.0 initiatives for supply chain sustainability in emerging economies. *Process Saf. Environ. Prot.* 117, 168–179.
- Luthra, S., Kumar, A., Zavadskas, E.K., Mangla, S.K., Garza-Reyes, J.A., 2020. Industry 4.0 as an enabler of sustainability diffusion in supply chain: an analysis of influential strength of drivers in an emerging economy. *Int. J. Prod. Res.* 58, 1505–1521.
- Mafakheri, F., Nasiri, F., 2014. Modeling of biomass-to-energy supply chain operations: applications, challenges and research directions. *Energy Policy* 67, 116–126.
- Mamdani, E., Assilian, S., 1993. An experiment in linguistic synthesis with a fuzzy logic. In: *Readings in Fuzzy Sets for Intelligent Systems*. Dubois. Morgan Kaufmann Publishers, Inc., Los Altos, CA, pp. 283–289.
- Manavalan, E., Jayakrishna, K., 2019. A review of internet of things (iot) embedded sustainable supply chain for industry 4.0 requirements. *Comput. Ind. Eng.* 127, 925–953.
- Mastrocinque, E., Ramírez, F.J., Honrubia-Escribano, A., Pham, D.T., 2020. An ahp-based multicriteria model for sustainable supply chain development in the renewable energy sector. *Expert Syst. Appl.* 150, 113321.
- Ministry of Economic Development, 2019. FER1 decree. Technical report. URL: Italian Government (accessed:21.03.15). <https://www.gazzettaufficiale.it/>.
- Mondragon, A.E.C., Mastrocinque, E., Tsai, J.F., Hogg, P.J., 2021. An ahp and fuzzy ahp multifactor decision making approach for technology and supplier selection in the high-functionality textile industry. *IEEE Trans. Eng. Manag.* 68 <https://doi.org/10.1109/TEM.2019.2923286>, 1112|1125.
- Mota, B., Gomes, M.I., Carvalho, A., Barbosa-Povoa, A.P., 2015. Towards supply chain sustainability: economic, environmental and social design and planning. *J. Clean. Prod.* 105, 14–27.
- Nara, E.O.B., da Costa, M.B., Baierle, I.C., Schaefer, J.L., Benitez, G.B., do Santos, L.M.A.L., Benitez, L.B., 2021. Expected impact of industry 4.0 technologies on sustainable development: a study in the context of brazil's plastic industry. *Sustain. Prod. Consum.* 25, 102–122.
- OFGEM, 2020. Feed-In Tariff (FIT) rates. Technical report. URL: ofgem, UK <https://www.ofgem.gov.uk/environmental-programmes/fit/fit-tariff-rates/>. (Accessed 21 May 2008).

- Piccarozzi, M., Silvestri, C., Aquilani, B., Silvestri, L., 2022. Is this a new story of the 'two giants'? A systematic literature review of the relationship between industry 4.0, sustainability and its pillars. *Technol. Forecast. Soc. Chang.* 177, 121511.
- Probst, L., Lefebvre, V., Martínez-Díaz, C., Bohn, N., Klitou, D., Conrads, J., 2018. In: *Digital Transformation Scoreboard 2018-eu Businesses Go Digital: Opportunities, Outcomes and Uptake*. Publications Office of the European Union, Luxembourg, p. 138.
- Psomas, S., 2018. *Status and Outlook of the Greek PV Market*. Technical Report. Hellenic Association of Photovoltaic Companies.
- PVTECH, 2020. *Greece tariffs*. Technical report. URL: PVTECH, Greece <https://www.pv-tech.org/tariffs/greece/>. (Accessed 21 May 2008).
- Ramírez, F.J., Honrubia-Escribano, A., Gómez-Lázaro, E., Pham, D.T., 2017. Combining feed-in tariffs and net-metering schemes to balance development in adoption of photovoltaic energy: comparative economic assessment and policy implications for European countries. *Energy Policy* 102, 440–452.
- REN21, 2019. *Renewables 2019 Global Status Report*. Technical Report. Renewable Energy Policy Network for the 21st Century.
- Scharl, S., Praktikno, A., 2019. The role of a digital industry 4.0 in a renewable energy system. *Int. J. Energy Res.* 43, 3891–3904.
- Seuring, S., 2013. A review of modeling approaches for sustainable supply chain management. *Decis. Support. Syst.* 54, 1513–1520.
- Solar Power Europe, 2020. *Global Market Outlook for Solar Power 2020-2024*. Technical Report. Solar Power Europe.
- Soni, G., Kumar, S., Mahto, R.V., Mangla, S.K., Mittal, M., Lim, W.M., 2022. A decision-making framework for industry 4.0 technology implementation: the case of fintech and sustainable supply chain finance for smes. *Technol. Forecast. Soc. Chang.* 180, 121686.
- de Sousa Jabbour, A.B.L., Jabbour, C.J.C., Foropon, C., Godinho Filho, M., 2018. When titans meet: can industry 4.0 revolutionise the environmentally-sustainable manufacturing wave? The role of critical success factors. *Technol. Forecast. Soc. Chang.* 132, 18–25.
- Stević, Z., Pamučar, D., Puška, A., Chatterjee, P., 2020. Sustainable supplier selection in healthcare industries using a new mcdm method: measurement of alternatives and ranking according to compromise solution (marcos). *Comput. Ind. Eng.* 140, 106231.
- Stock, T., Obenaus, M., Kunz, S., Kohl, H., 2018. Industry 4.0 as enabler for a sustainable development: a qualitative assessment of its ecological and social potential. *Process Saf. Environ. Prot.* 118, 254–267.
- Sung, T.K., 2018. Industry 4.0: a Korea perspective. *Technol. Forecast. Soc. Chang.* 132, 40–45.
- Takagi, T., Sugeno, M., 1985. Fuzzy identification of systems and its applications to modeling and control. *IEEE Trans. Syst. Man Cybern.* 116–132.
- Thoben, K.D., Wiesner, S., Wuest, T., 2017. "Industrie 4.0" and smart manufacturing—a review of research issues and application examples. *Int. J. Autom. Technol.* 11, 4–16.
- Tsao, Y.C., Thanh, V.V., Lu, J.C., Wei, H.H., 2021. A risk-sharing-based resilient renewable energy supply network model under the covid-19 pandemic. *Sustain. Prod. Consum.* 25, 484–498.
- UNIDO, 2017. *Accelerating Clean Energy Through Industry 4.0: Manufacturing the Next Revolution*. Technical Report. United Nations Industrial Development Organization.
- Wang, C.N., Huang, Y.F., Chai, Y.C., Nguyen, V.T., et al., 2018. A multi-criteria decision making (MCDM) for renewable energy plants location selection in Vietnam under a fuzzy environment. *Appl. Sci.* 8, 2069.
- Wang, C.N., Yang, C.Y., Cheng, H.C., 2019. Fuzzy multi-criteria decision-making model for supplier evaluation and selection in a wind power plant project. *Mathematics* 7, 417.
- WCED, U.N., 1987. *Our common future*. In: *World Commission on Environment and Development*. Oxford University Press.
- Xu, T., Ma, J., 2021. Feed-in tariff or tax-rebate regulation? Dynamic decision model for the solar photovoltaic supply chain. *Appl. Math. Model.* 89, 1106–1123.
- Yakovleva, N., Sarkis, J., Sloan, T., 2012. Sustainable benchmarking of supply chains: the case of the food industry. *Int. J. Prod. Res.* 50, 1297–1317.
- You, F., Tao, L., Graziano, D.J., Snyder, S.W., 2012. Optimal design of sustainable cellulosic biofuel supply chains: multiobjective optimization coupled with life cycle assessment and input-output analysis. *AIChE J.* 58, 1157–1180.
- Yuce, B., Mastrocinque, E., 2016. A hybrid approach using the bees algorithm and fuzzy-ahp for supplier selection. In: *Handbook of Research on Advanced Computational Techniques for Simulation-based Engineering*. IGI Global, pp. 171–194.
- Zadeh, L.A., 1965. Information and control. *Fuzzy Sets* 8, 338–353.
- Zhu, Q., Lai, K.H., 2019. Enhancing supply chain operations with extended corporate social responsibility practices by multinational enterprises: social capital perspective from Chinese suppliers. *Int. J. Prod. Econ.* 213, 1–12.

Ernesto Mastrocinque is Senior Lecturer in the Faculty of Engineering, Environment and Computing of Coventry University (UK). His research interests include decision-making and optimisation in the areas of supply chain management, manufacturing systems, sustainable development and Industry 4.0. He has developed different methodologies based on multi-criteria decision-making approaches, meta-heuristics algorithms, machine learning techniques and fuzzy logic. His research work has been published on a number of reputable journals.

F. Javier Ramírez is Tenured Professor of Operations Management at the University of Castilla-La Mancha (Spain). Ramírez's research focuses on innovation and optimisation models. He has been the main researcher or collaborator in more than 120 R&D projects and contracts for public and private institutions. He has co-authored over 50 research papers in journals, specialized conferences and book chapters, and he is co-inventor of 6 patents with industrial exploitation.

Andrés Honrubia-Escribano is Associate Professor in the Department of Electrical, Electronics and Control Engineering of the University of Castilla-La Mancha (Spain). He holds a Ph.D. in Renewable Energy from the Technical University of Cartagena (Spain). He has worked for several research institutions, such as the University of Castilla-La Mancha, the University of Jaen, the Technical University of Cartagena, Fundacion CIRCE (Centre of Research for Energy Resources and Consumption). He has published more than 100 articles in journals, books and specialized conferences as well as he has collaborated in more than 60 R&D projects, both public and private-funded. He has also collaborated as External Expert for the evaluation of Project proposals for the European Commission. His main research interest is the integration of wind energy into power systems.

Duc T. Pham OBE FEng FSME FIET FIMEChE PhD DEng holds the Chance Chair of Engineering at the University of Birmingham where he started his career as a lecturer in robotics and control engineering following undergraduate and postgraduate studies at the University of Canterbury in New Zealand. Prior to returning to Birmingham in 2011, he was Professor of Computer-Controlled Manufacture and Director of the Manufacturing Engineering Centre at Cardiff University. His research is in the areas of intelligent systems, robotics and autonomous systems and advanced manufacturing technology.